

SHARP



Refrigerant: R600a

Insulation blowing gas: Cyclopentane

冷媒種類 : R600a

絕緣發泡材主要成份 : 環戊烷

香港電器安全規格

(國際電工委員會規格適合)

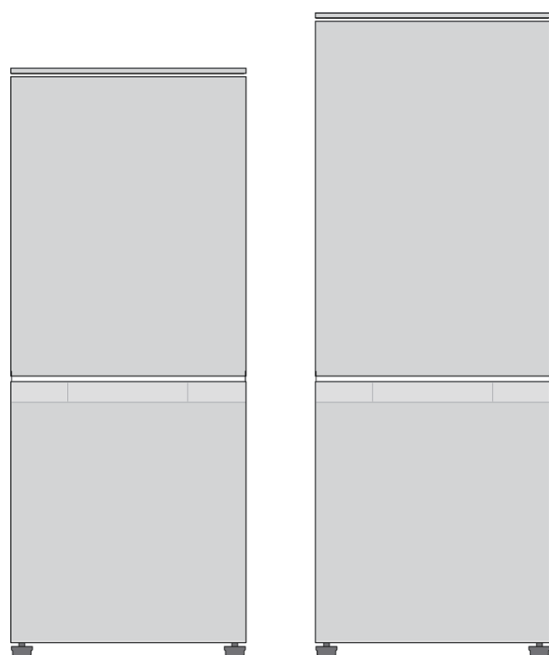

SJ-BR15G

SJ-BR18G

SJ-BR15G

SJ-BR18G

Refrigerator - Freezer Operation manual

Contents

• Safety information	2
• Installation	4
• Description	5
• Controlling temperature	6
• Storing food	7
• Care and cleaning	8
• Before calling for service	9

原裝進口雪櫃 使用說明書

目錄



• 安全注意事項	11
• 安裝	13
• 各部位名稱	14
• 調節溫度	15
• 食品的儲存	16
• 保養	17
• 送修之前的初步檢查	18

Thank you very much for buying this SHARP product. Before using your SHARP refrigerator, please read this operation manual to ensure that you gain the maximum benefit from it.

- This refrigerator is intended for making ice cubes, refrigerating and freezing food.
- This refrigerator is for household use only, with ambient temperature indicated between +5°C and +38°C.
- The refrigerator should not be subjected to temperatures of -10°C or below for a long period of time.

Household use only

Safety information

	Warning	This means that there are high risks of death or serious injury.
	Caution	This means that there are high risks of material damage or personal injury.
	Caution	Fire marks means this refrigerator has risk of fire accident.



Warning

Refrigerant

This refrigerator contains flammable refrigerant (R600a: isobutane) and insulation blowing gas (cyclopentane). Observe the following rules to prevent ignition and explosion.

- Do not damage the refrigerant circuit.
- Do not allow any sharp objects to have contact with the refrigeration system. The refrigeration system behind and inside the refrigerator contains refrigerant. Leaking refrigerant can ignite and may damage the eyes.
- Do not use mechanical devices or other means to accelerate the defrosting process. (This refrigerator has adopted automatic defrosting system.)
- Do not use electrical appliances inside the refrigerator.
- Do not block the space around the refrigerator.
- Do not use flammable sprays, such as spray paint near the refrigerator.
- Do not store flammable sprays, such as spray paint in the refrigerator.
- In the case of failure of the refrigeration system, do not touch the wall socket and use open flames. Open the window and air out the room. Then ask a service agent approved by SHARP for service.

Power cord, Plug, Socket

Read carefully the following rules to prevent electric shock or fire.

- Make sure to protect the power cord from being damaged during installation or moving. If the power plug or cord is loose, do not insert the power plug.
- Do not place multiple portable socket-outlets or portable power supplies at the rear of the refrigerator.
- Connect the power plug into the wall socket firmly and directly. Do not use an extension cord or adapter plug.
- Connect the power plug to the socket with the required rated voltage.
- Connect the earth pin to the earth terminal properly.
- Do not touch the power plug with wet hands.

- Disconnect from the main electricity supply by removing the main plug from the socket. Do not remove by pulling the power cord.
- Dust deposited on the power plug may cause fire. Wipe it off carefully.
- Pull out the plug if the refrigerator is not used for a long time.
- If the flexible supply cord is damaged, it must be replaced by service agent approved by SHARP in order to avoid a hazard.

Installation

- Do not install the refrigerator in a damp or wet location. It may cause the damage to the insulation or electrical leak. Dew may also appear on the outer cabinet and it causes rust.
- The refrigerator should be installed flatly and firmly on the floor.
- Keep ventilation openings.

In use

- Do not store volatile and flammable materials such as ether, petrol, propane gas, aerosol cans, adhesive agents and pure alcohol etc. These materials are easy to explode.
- Do not store temperature-sensitive products such as pharmaceutical products in the refrigerator. There are high risks of changes in product quality.
- Do not attempt to change or modify this refrigerator. This may result in fire, electric shock or injury.
- Do not place a container filled with liquid on the top table.
- Do not place unstable objects on the top table or add significant weight in front of the step.
- This appliance can be used by children aged from 8 years or above and persons with reduced physical, sensory or mental capabilities or lack of experience and knowledge if they have been given supervision or instruction concerning use of the appliance in a safe way or understanding the hazards involved. Children shall not play with the appliance. Cleaning and user maintenance shall not be done by children without supervision.

Care and Cleaning

- Unplug the refrigerator first to prevent electric shock.
- Do not splash water directly on the outer cabinet or the interior. This may lead to rusting and deterioration of the electrical insulation.

Trouble

- If you smell something burnt, pull out the power plug immediately. Then ask a service agent approved by SHARP for service.
- In case of gas leak, ventilate the area by opening window. Do not touch the refrigerator or the power socket.



Caution

Transportation

- When you install or move your refrigerator, use curing mat to protect the floor from being damaged.
- Carry the refrigerator securely. If you lift up the refrigerator improperly, it may cause injury.

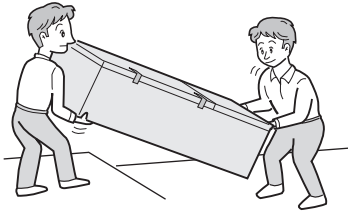

Disposal

- Ensure that the refrigerator presents no danger to children while being stored for disposal. (e.g. remove the magnetic door seals to prevent child entrapment.)
- This refrigerator should be disposed appropriately. Take the refrigerator to a professional recycling plant for flammable refrigerant and insulation blowing gases.

In use

- Do not touch the compressor unit or its peripheral parts, as they become extremely hot during operation and the metal edges may cause injury.
- Do not touch food or metal containers in the freezer compartment with wet hands. This may cause frostbite.
- Do not use other than potable water to make ice cubes.
- Do not place bottled drinks and cans in the freezer compartment as they may crack when frozen.
- Do not open or close the door when other people put a hand near the door. There is a risk that the other people may get their fingers caught in the door.
- Make sure not to put your hands on the shaded area below when you close the door. It may cause injury.

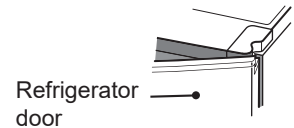

- Do not put oversized object in the pockets of the door. If the object falls down from the pockets, it may cause injury.
- Make sure to handle the glass shelves with care to install or uninstall. If you drop the glass shelves, it may break or cause injury.

- 1** Keep adequate ventilation space around the refrigerator.
The picture shows the minimum required space for installing the refrigerator. The measurement condition of energy consumption is conducted under a different space dimension.

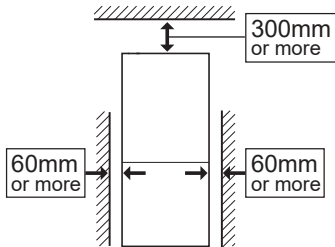

Rear clearance

The space between the rear of the refrigerator and the wall should be 50mm or more, and less than 75mm. If the space is wider than 75mm, you may get injured by touching compressor and its peripheral parts which are extremely hot during the operation.

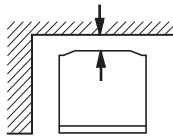

Note

- By keeping greater space, the refrigerator may consume a less amount of power consumption.
- If use the refrigerator in the smaller space dimension than figured, it may cause temperature rise in the unit, loud noise and failure.
- Do not push the refrigerator against the wall. The wall surrounding the refrigerator may get dirty or discolored because of the air flow caused by heat radiation.

Overall space required in use

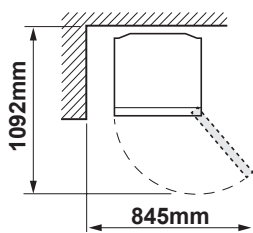

Make sure that there is enough space for the doors to open fully. Otherwise, you may not be able to slide the shelves or drawers completely.

How to install the refrigerator

Use adjustable feet (2 places) to stable the refrigerator for preventing noise and vibration.

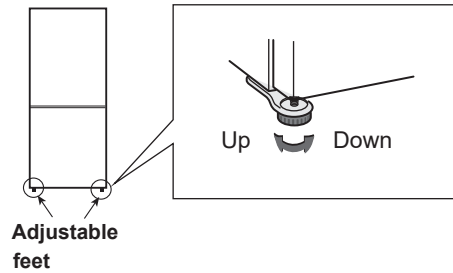

1. Lift up the bottom of the refrigerator slightly and turn the adjustable feet.
2. Down the refrigerator straight and check following points.
 - Are adjustable feet reach to the floor?
 - Is the refrigerator stabled?
 - Is the refrigerator put vertically?
- Freezer door might open by opening of refrigerator door. This motion is not a problem because it is caused by wind pressure of door opening.
- Turn the adjustable feet a little to lift up the front part of the refrigerator if the refrigerator door is not closed completely.

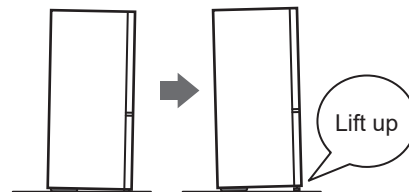

Note

- Place your refrigerator to access the plug.
- Keep your refrigerator out of direct sunlight and do not place next to heat generating appliance.

Changing the direction of door opening

- The direction of door opening can be changed. Make sure to ask the service center authorized by SHARP if necessary.
- Hole cover sticker is enclosed for spare with the operation manual. The sticker is for the repairman. Make sure to keep it.

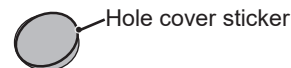

Before using your refrigerator

Clean the inside parts with a cloth soaked in warm water. If soapy water is used, wipe it off thoroughly with water.

Description

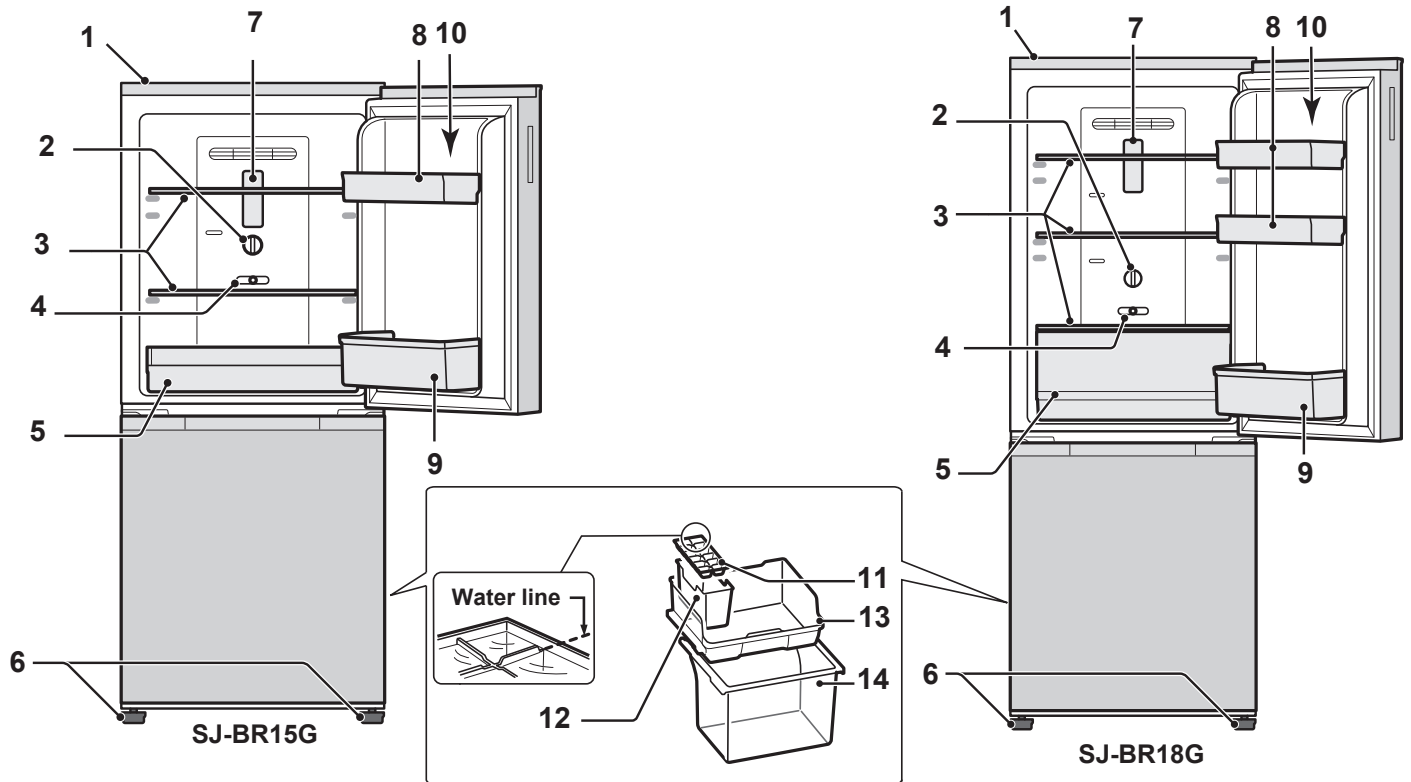

1. Top table

You can put a microwave etc.

- Upper-temperature limit : 100°C.
- Withstand load : 30kg

Do not place any objects in front of the step.

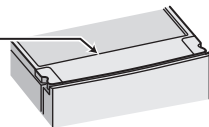

- Note:**
- The dimensions between the legs of a microwave (outside) should be within 410 mm (width) and 340 mm (depth). Make sure to put the microwave in the center of the top table.
 - Do not place a toaster oven or other devices that the surface temperature becomes over 100°C.

2. Temperature control knob

3. Glass shelf

- (SJ-BR15G : 2 pcs.)
(SJ-BR18G : 3 pcs.)

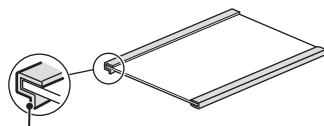

The protrusion must be on the bottom side at the back to prevent the shelf from falling down.

4. Temperature control lever

5. Free case (SJ-BR15G)

5. Fresh case (SJ-BR18G)

6. Adjustable feet (2 pcs.)

7. Light

8. Refrigerator door pocket (SJ-BR15G : 1 pc.) (SJ-BR18G : 2 pcs.)

9. Bottle pocket

10. Egg tray

11. Ice cube tray

12. Ice storage box

This case is used for the stock of ice cubes. You can also use this as an utility case when there is no ice cube in the case.

13. Freezer tray

Make sure not to pull this case forward or backward strongly when the ice cube tray (No.11) is filled with water. Water may spill out.

14. Freezer case

Deodorizing unit (Only for SJ-BR18G)

Deodorizing catalyst is installed on the routes of cold air. There is no need to operate and clean.

Description

If you wish to store large items within your refrigerator

You can remove Freezer tray, Freezer case and Freezer bar to keep large items .

- ① Hold the rail and pull the door out.

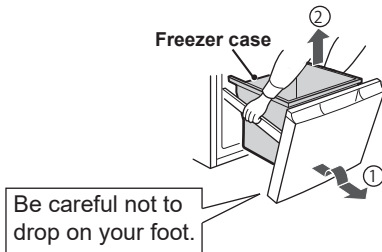

- ② Remove Freezer tray and Freezer case.

- ③ Remove Freezer bar.

1. Slide the caps(2 places) inward.
2. Pull the freezer bar forward.
3. Slide the bar slightly inward.
4. Lift the bar up.

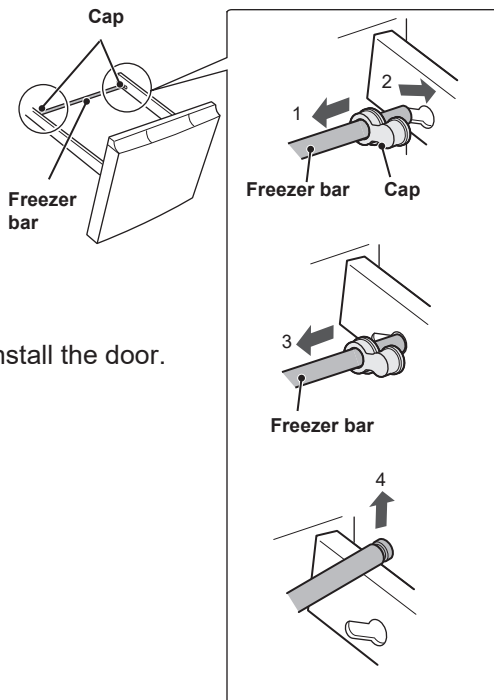

- ④ Install the door.

Installation is in an opposite way to remove.

Controlling temperature

Temperature control knob for refrigerator compartment

Use this knob to change the level of cooling.

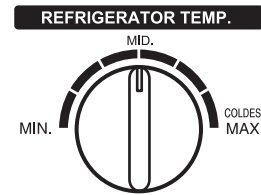

MIN	It is higher 2°C to 3°C than "MID".
MID	<ul style="list-style-type: none"> • For normal use • Refrigerator compartment (center) is approx 3°C. (Condition: Outside temperature is 30°C and temperature control lever is set at "MID".) *1
MAX	It is lower 2°C. to 3°C than "MID".

*1 : Freezer compartment (center) is approx. -18°C under this condition.

• The temperature of freezer compartment is also changed by the settings above.

Temperature control lever for freezer compartment

Use this lever to change the balance of cold air of refrigerator compartment and freezer compartment.

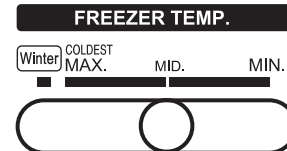

MIN	When the amount of frozen food is not so much.(This is to decrease the cold air flow into the freezer compartment.)
MID	For normal use
MAX *2	<ul style="list-style-type: none"> • When freezer compartment is not cooled enough.(This is to increase the cold air flow into the freezer compartment.) • When you want to freeze the food quickly.
Winter	In winter (when the ambient temperature is under 10 °C.)

*2 : The refrigerator compartment may not be cooled enough because of this setting. In that case, make sure to move the lever to "MID".

Note

Make sure not to set the temperature of freezer compartment to " Winter" when the ambient temperature is above 10°C because the refrigerator compartment is not cooled enough. Move the knob to other settings (MAX-MIN).

Storing food

Refrigeration reduces the rate of food spoilage. Ensure that the food is of the freshest possible quality to maximize the shelf life of perishable food. The following is a general guide to help promote longer food storage.

Fruit / Vegetables

Fruit and vegetables should be loosely enclosed in a plastic material e.g. wrap, bags (do not seal) and placed in the vegetable crisper to minimize moisture loss.

Dairy Products & Eggs

- Most dairy products have their best-before date on the outer packaging which informs the recommended temperature and shelf life of the food.
- Eggs should be stored in the Egg tray.

Meat / Fish / Poultry

- Place on a plate or a dish and cover with paper or plastic wrap.
- For larger cuts of meat, fish, or poultry, place to the rear of the shelves.
- Ensure all cooked food is wrapped securely or placed in an airtight container.

* Notes for fresh food:

- Fresh food (securely wrapped) should be stored in limited time to prevent spoilage and badly affecting other stored foods.

For best freezing

- Quality of food should be fresh.
- Freeze small quantities of food at a time in order to freeze them quickly.
- Food should be properly sealed or covered tightly.
- Place food in the freezer evenly.
- Label bags or containers to keep an inventory of freezing food.

Advice for preventing dew or frost inside the refrigerator

- Make sure to put the food on the shelf or in the pocket. If the food falls down, the door is not closed securely.
- Food with high-moisture should be stored in airtight container or sealed tightly.

Note

- Place the food evenly on the shelves to allow the cooling air to circulate efficiently.
- Hot food should be cooled before storing. Storing hot food increases the temperature in the unit and the risk of food spoilage.
- Opening the door for long periods can cause a significant increase of the temperature in the compartments of the appliance.
- Do not block the outlet and inlet of the cool air circulating circuit with food or containers; otherwise the food can not be evenly cooled throughout the refrigerator.

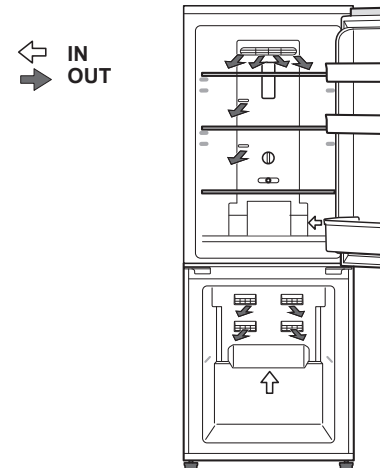

Do not place food directly in front of cold air outlet. This may lead to the food freezing.

Care and cleaning

Important

To prevent cracks on inside surfaces and plastic components, follow these tips.

- Wipe out food oil adhered to plastic parts.
- Some household chemicals may cause damage, so use only diluted washing-up liquid (soapy water).
- If undiluted detergent is used or soapy water is not wiped off thoroughly, it may result in cracks of plastic parts.

Cleaning

- Remove the accessories (e.g. shelves) from the cabinet and the door. Wash them by warm soapy dishwashing water. After that, rinse them in clean water and dry.
- Clean the inside with a cloth soaked in warm soapy dishwashing water. Then, use cold water to wipe off soapy water thoroughly.
- Wipe the exterior with a soft cloth each time it gets dirty.
- Clean the Magnetic door seal with a toothbrush and warm soapy dishwashing water.

Note

- Do not use heavy-duty cleansers or solvents (lacquer, paint, polishing powder, benzine, boiled water, etc.) which may cause damages.
- If you pull out the power plug once, wait 6 minutes at least before connecting the power plug again.
- Do not drop objects inside the refrigerator or strike the inner wall. This may cause cracks to inner surface.
- Make sure not to drop the glass shelves when you remove them from the cabinet.

Defrosting

Frost on the cooling equipment (hidden from the outside) is melted regularly and fall into the evaporating pan. After that, the water is dried up by the heat of compressor.

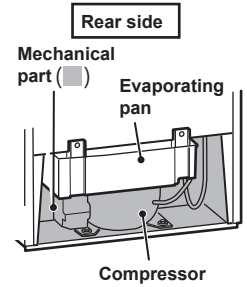

When the compartment light is blown

Contact the service agent approved by SHARP to replace the light. The light is not to be replaced other than by qualified service personnel.

Switching off your refrigerator

If the refrigerator needs to be switched off for an extended period, the following steps should be taken to reduce the growth of mold:

1. Remove all food.
2. Remove the power plug from the socket.
3. Clean and dry the interior thoroughly.
4. Keep all the doors open slightly for a few days to dry.

Before calling for service

Before calling for service, check the following points.

Problem	Solution
The outside of the cabinet is hot when touching.	It is normal. The hot pipe is in the cabinet in order to prevent dew generation.
When there is refrigerator noise.	It is normal for the refrigerator to make the following sounds. <ul style="list-style-type: none"> • Loud noise is made by the compressor when its operation starts <ul style="list-style-type: none"> -- Sound becomes quieter after a while. • The compressor makes loud noise once a day. <ul style="list-style-type: none"> -- Operating sound is made immediately after automatic defrost operation. • Sound of flowing fluid (gurgling sound, fizzing sound) <ul style="list-style-type: none"> -- Sound of refrigerant flowing in pipes (sound may become louder from time to time). • Cracking or crunching sound, squeaking sound <ul style="list-style-type: none"> -- Sound produced by expansion and contraction of inner walls and internal parts during cooling.
Refrigerator compartment is not cooled enough.	<ul style="list-style-type: none"> • Is the temperature setting of freezer compartment set at "Winter" in summer ? <ul style="list-style-type: none"> -- Move the freezer lever to other settings." MID" is recommended.
Freezer compartment is not cooled enough.	<ul style="list-style-type: none"> • Is the temperature setting of refrigerator compartment set at "MIN" side? <ul style="list-style-type: none"> -- Move the refrigerator knob to "MAX" side. • Is the temperature setting of freezer compartment set at "MID" in winter? <ul style="list-style-type: none"> -- Move the freezer lever to "Winter" side.
The food in the refrigerator compartment freeze.	<ul style="list-style-type: none"> • Is the refrigerator operated for a long time with the temp. control knob set at "MAX" ? <ul style="list-style-type: none"> -- Change the temperature control to other setting. • If ambient temperature is low, food may freeze even if the refrigerator knob is set to "MIN" <ul style="list-style-type: none"> -- Move the freezer lever to "Winter" side.
Frost or dew appears inside or outside the refrigerator.	This may occur in one of the following cases. Use a wet cloth for wiping frost and a dry cloth for wiping dew. <ul style="list-style-type: none"> • When the ambient humidity is high. • When the door is frequently opened and closed. • When food containing plenty of moisture is stored. (Wrapping is required.)
Ice cubes are rounded.	<ul style="list-style-type: none"> • Ice cubes might be rounded if they are kept for a long time.
When you close the door, the other door is opened.	<ul style="list-style-type: none"> • The door might open because of the wind pressure, amount of food and the condition of the floor. <ul style="list-style-type: none"> -- Turn the adjustable feet to lift up the front part of the refrigerator if the refrigerator door is not closed.
The floor is wet.	<ul style="list-style-type: none"> • Check if the door packings are damaged or not. If the packings are damaged, frost on the cooling equipment becomes thicker than usual and water may overflow from the evaporating pan.
Odors in the compartment.	<ul style="list-style-type: none"> • Wrapping is required for the food with strong odors. • Deodorizing unit cannot remove all odors.(Only for SJ-BR18G)

Before calling for service

Before calling for service, check the following points.

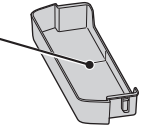
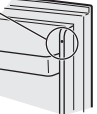
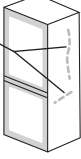
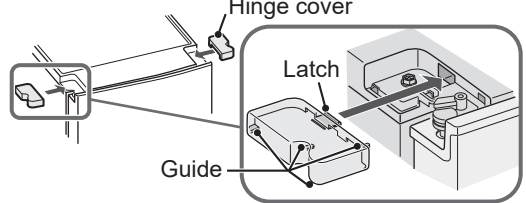
Problem	Solution
<p>The parts or inside wall have lines, holes and dents.</p>	<ul style="list-style-type: none"> Following things are not problems. These are caused by the production process of parts or products. <div style="display: flex; justify-content: space-around; align-items: flex-start;"> <div style="text-align: center;">  <p>Line</p> </div> <div style="text-align: center;">  <p>Small holes of the doors. (Many points)</p> </div> <div style="text-align: center;">  <p>Waves or distortions of the side of the refrigerator. (You might see them by the direction of the light.)</p> </div> </div>
<p>The compartment light is flashing.</p>	<ul style="list-style-type: none"> It shows the breakdown of the electrical parts. Make sure to ask the service center authorized by SHARP to repair. (Cooling operation does not stop. However, the inside is cooled too much or not cooled enough.)
<ul style="list-style-type: none"> Hinge cover is not fit securely. Hinge cover comes off. 	<ul style="list-style-type: none"> Make sure to follow the instructions below to attach. -- Push the hinge cover as following picture to fit the latch and the guides (4 places) . <div style="text-align: center;">  <p>Hinge cover</p> <p>Latch</p> <p>Guide</p> </div>

If you still require service



Refer to your nearest service agent approved by SHARP.

感謝您購買 SHARP 產品。在使用 SHARP 雪櫃之前，為使您能夠充份使用您所購買的雪櫃，請仔細閱讀本使用說明書。

- 本雪櫃可用於製作冰塊、冷藏和冷凍食物。
- 這個雪櫃僅限於家庭用途，使用雪櫃的環境溫度為 +5°C 和 +38°C 之間。
- 雪櫃在一段長時間內不應受到 -10°C 或以下的溫度。

僅限於家庭用途

安全注意事項

 警告	這表明導致死亡或重傷的風險很高。
 安全注意事項	這表明導致材料受損或人員受傷的風險很高。
 安全注意事項	火焰標誌表示此裝置有發生火災事故的風險。

警告

冷媒

雪櫃含有易燃製冷劑（R600a：異丁烷）和絕熱發泡氣體（環戊烷）。為防止著火和爆炸，請遵守以下規則。

- 請勿破壞製冷回路。
- 雪櫃內部及後側的製冷系統內含有製冷劑。請務必避免任何尖銳的物體碰觸製冷系統。洩漏的製冷劑會著火且可能傷害眼睛。
- 請勿使用機械設備或其他方式來加速除霜過程。（此雪櫃已採用自動除霜系統）
- 請勿在雪櫃內使用電器。
- 請勿堵塞雪櫃周圍的空間。
- 請勿在雪櫃附近使用易燃性噴霧劑，例如噴漆，否則可能會導致爆炸或火災。
- 請勿在雪櫃附近儲藏如噴漆等易燃性噴霧罐。
- 如果雪櫃的冷卻系統上有損毀，請勿接觸牆壁電源插座，也勿使用明火。打開窗戶，使房間空氣流通。然後聯繫 SHARP 認可的售後服務中心進行維修。

電源線，插頭，插座

為防止觸電或火災，請仔細閱讀以下規則。

- 在安裝或移動的過程中，請確保電源線完好無損。如果電源插頭或電源線出現鬆動等情況，請勿插入電源插頭。
- 請勿在雪櫃後部放置多個移動式插座或移動電源。
- 直接將電源插頭插入牆壁電源插座。請勿使用延長的電線或轉換插頭。
- 將電源插頭插入符合額定電壓要求的插座上。
- 正確地將接地線連接到接地端子。
- 請勿用濕手接觸電源插頭。

- 拔出電源插頭時，請不要只拉住電源線，應該拿住插頭端拔出。
- 電源插頭上積滿灰塵是引起火災的原因。因此，請時常將其擦淨。
- 雪櫃如果長時間不使用，請將插頭拔出。
- 電源線損壞時，請到 SHARP 認可的售後服務中心更換，以免造成危險。

安裝

- 請勿將雪櫃設置在潮濕的地方。這樣會因絕緣失效而導致漏電。而且有時會在雪櫃外側結露。
- 將雪櫃穩妥地安裝在地板的水平位置上。
- 保持通風通暢。

使用中

- 請勿儲藏揮發性物質和易燃性物質，如乙醚、汽油、丙烷氧、粘合劑、純乙醇等。此類物質有爆炸之危險。
- 請勿在雪櫃內儲存溫度敏感型產品，例如醫藥產品。否則產品極可能會變質。
- 請勿改裝雪櫃。修理技術人員以外的人員拆卸和修理本機，會導致火災、觸電和受傷。
- 請勿將裝有液體的容器置於機頂表面上。
- 請勿將不穩定的物體置放在機頂表面上或在間隙前增加額外重量。
- 此雪櫃適合 8 歲及以上的兒童使用。在有符合電器使用安全的監督或指導及了解潛在危險的前提下，此雪櫃也適合身體、感官或智力方面有缺陷的殘障人士、或者缺乏相關經驗或知識的人士使用。禁止讓兒童玩弄雪櫃。在無任何監督的情況下，兒童不得對雪櫃進行清潔及維修保養。

保養

- 為了防止觸電，首先拔掉雪櫃的電源插頭。
- 請勿直接將水灑在雪櫃的內部和外部。這樣會導致生鏽及絕緣性能下降。

故障

- 如果聞到燒焦的味道，請立即拔出電源線，然後聯繫 SHARP 認可的售後服務中心進行維修。
- 萬一發生瓦斯氣漏事故，請勿用手去觸摸雪櫃和插頭，要打開窗戶通風。



安全注意事項

運輸

- 安裝或移動雪櫃時，請使用防護墊以防止地板受損。
- 請妥善搬運雪櫃。如果抬起雪櫃的方式不當，可能會導致人員受傷。

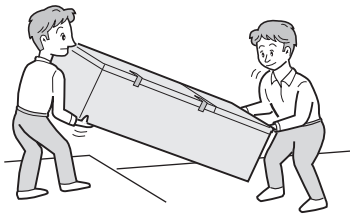

廢舊雪櫃的處理

- 確保雪櫃在等候處理的過程中不會給兒童帶來危險。（例如拆除門封以防兒童不慎卡入。）
- 請妥善處理雪櫃。雪櫃請運送至專業的可燃性製冷劑及絕熱發泡氣體廢料處理廠。

使用中

- 由於壓縮機單元或者其外圍部件在操作過程中將變得非常燙手，千萬不要去觸摸，否則，將會被金屬邊緣燙傷。
- 不要用濕手去觸摸冷凍室內的食品 and 金屬製容器。恐會導致手凍傷。
- 僅能使用飲用水製冰。
- 請勿將瓶裝或罐裝飲料放入冷凍室。
- 當其他人的手靠近雪櫃門時，請勿打開或關閉雪櫃門，否則雪櫃門會夾到其他人的手。
- 關門時，請確保不要將手放在下面的陰影區域。可能會造成傷害。

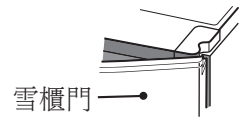

- 請勿在雪櫃門的雪櫃門架上放置尺寸過大的物品。如果該物品從雪櫃門架上掉落，可能會導致人員受傷。
- 安裝或拆下時，請確定小心處理玻璃層架。若不慎摔落玻璃層架，此層架可能會破裂或使人受傷。

- 1** 雪櫃的周圍應確保足夠的通風空間。圖中顯示出安裝雪櫃所需要的最低限度的空間。耗電量的測試需在不同空間條件下進行。

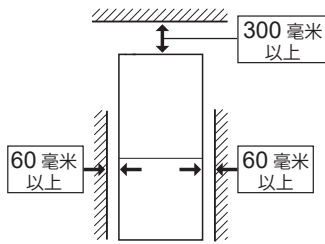

雪櫃後方間隙

雪櫃後部與牆體之間的空間距離應為大於 50 毫米且小於 75 毫米。若此空間大於 75 毫米，切勿觸摸在運行中過熱的壓縮機以及外圍部件，以免受傷。

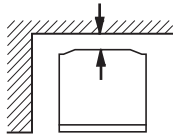

請注意

- 雪櫃周圍的空間越大，雪櫃運行時的耗電量越小。
- 若在小於以下圖所示尺寸的空間內使用雪櫃，可能會導致裝置溫度升高，噪音加大和其他故障。
- 請勿將雪櫃往牆的方向推。雪櫃周圍的牆壁會因熱輻射產生的氣流而變髒或褪色。

使用時所需總體空間

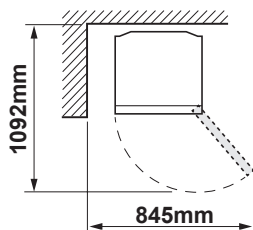

為了讓門可以完全打開，請確保有足夠的空間。否則，你可能無法完全滑動架或盒。

如何安裝雪櫃

使用調節腳（2 處）穩定雪櫃以防止噪音和振動。

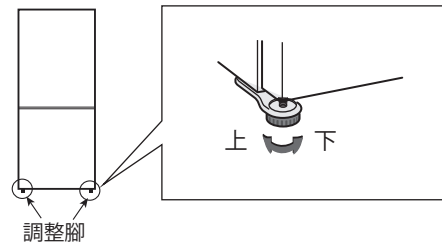

1. 輕輕抬起雪櫃底部並轉動調節腳。
 2. 直直放下雪櫃並檢查下列幾點。
 - 調整腳是否觸及地面？
 - 雪櫃是否穩定？
 - 雪櫃是否垂直置放？
- 打開冷藏門時可能會打開冰凍門。此現象不是問題，因為它是由開門風壓引起。
 - 若冷藏門無法完整關閉，微幅轉動調整腳以抬起雪櫃的前部。

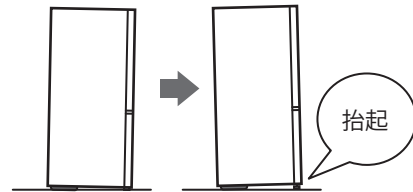

請注意

- 設置雪櫃時要充分考慮便於插拔電源插頭。
- 請勿將雪櫃放在陽光直射的地方或發熱機器的旁邊。

更改門開啟的方向

- 可以更改門開啟的方向。
- 務必依需求詢問 SHARP 授權的服務中心。
- 使用說明書隨附孔蓋貼紙以供備用。貼紙是供維修員使用。請務必保留。



在使用雪櫃前

用溫水浸泡過的軟布清潔雪櫃內部。如果使用肥皂液，請用水徹底擦掉殘留肥皂液。

各部位名稱

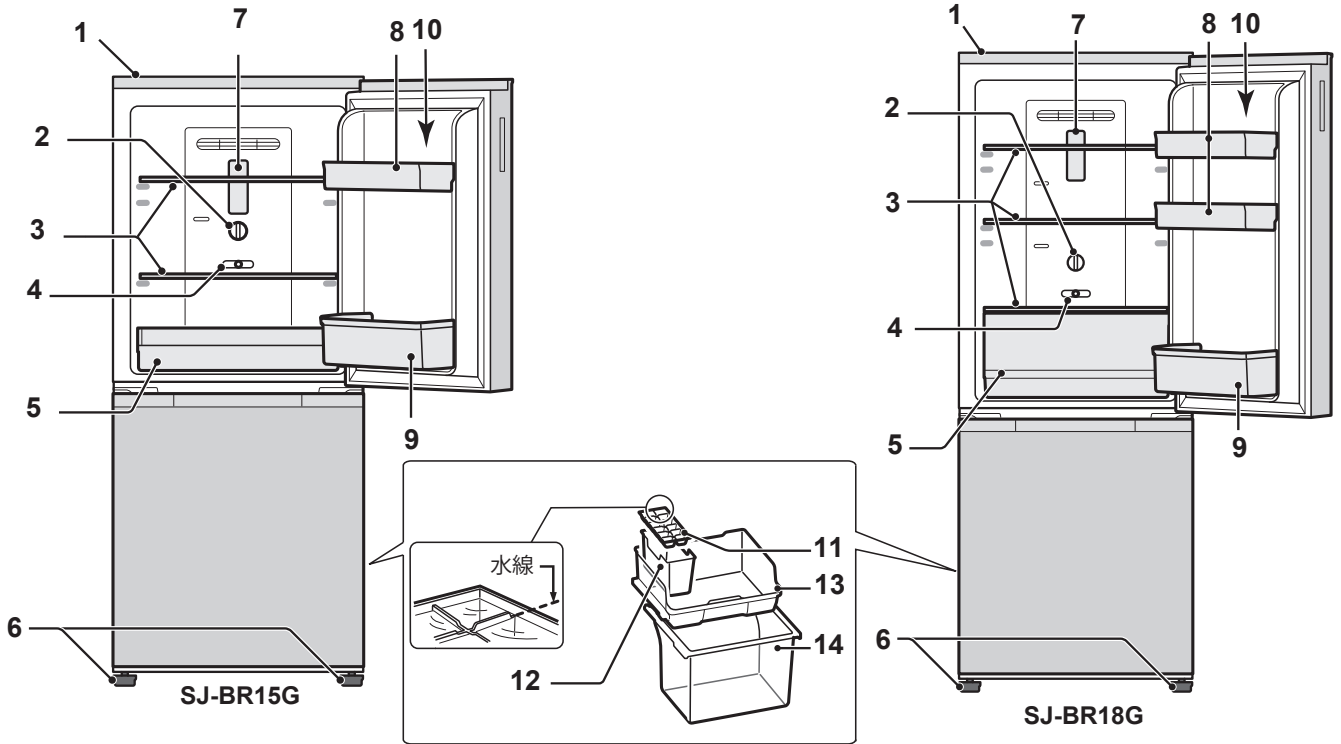

1. 機頂表面

- 您可以置
放微波爐等。
- 機頂溫度限制：100°C
 - 承受負載：30kg

請勿置
放物品在前端間隙上。

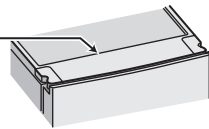

- 請注意：· 微波爐（外側）的腳架尺寸應介於 410 毫米（寬）和 340 毫米（深）內。
請確保微波爐置於機頂表面的中間。
· 請勿置
放烤吐司機或表面溫度超過 100°C 的其他
裝置。

2. 溫度調節旋鈕

3. 玻璃層架

- （ SJ-BR15G：2 件）
（ SJ-BR18G：3 件）

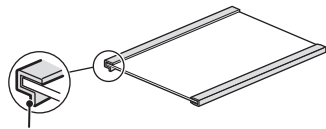

突出部分需在後面的底部，以防止層架掉落。

4. 溫度調節桿

5. 儲物盒（SJ-BR15G）

5. 保鮮盒（SJ-BR18G）

6. 調整腳（2 處）

7. 燈

8. 雪櫃門架

- （ SJ-BR15G：1 處）
（ SJ-BR18G：2 處）

9. 瓶架

10. 蛋架

11. 製冰盒

12. 儲冰盒

本盒的用途是儲存冰塊。
當盒內無冰塊時，可作為儲物盒。

13. 冷凍室層架

當製冰盒（編號 11）裝滿水時，請確保不要向前或
向後大力拉動此盒。水可能會溢出。

14. 冷凍盒

脫臭裝置（只為 SJ-BR18G）

已經將脫臭觸媒設置在冷氣的通道上。不需要進行操作和
清潔。

各部位名稱

若您想要在雪櫃內儲藏大型物品

您可以移除冷凍層架、冷凍盒和冷凍桿以置放大型物品。

① 握住滑軌，將門拉出。

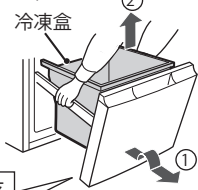

請小心勿掉落至您的腳上。

② 移除冷凍層架和冷凍盒。

③ 移除冷凍桿。

1. 將蓋子 (2 處) 向內滑動。
2. 向前拉冷凍桿。
3. 將桿稍微向內滑動。
4. 將桿抬起。

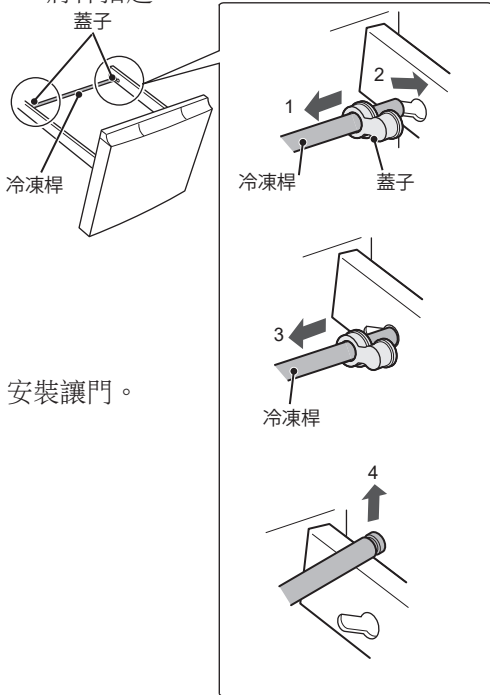

④ 安裝讓門。

安裝與拆卸方式相反。

調節溫度

冷藏室的溫度調節旋鈕

使用此旋鈕以更改冷卻程度。

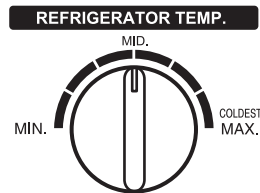

MIN	比「MID」高 2°C ~ 3°C。
MID	· 正常使用 · 冷藏室 (中間) 大約是 3°C。 (條件: 室外溫度為 30°C, 溫度控制桿設置為 "MID") *1
MAX	比「MID」低 2°C ~ 3°C。

*1: 冷凍室 (中心) 約 -18°C 下這種情況。

· 冷凍室的溫度也可由下列設定更改。

冷凍室的溫度調節桿

使用此桿以更改冷藏室和冷凍室間的冷空氣平衡。

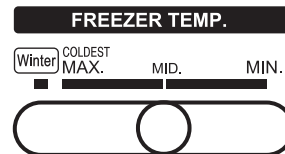

MIN	當含有少許冷凍食物時。 (這是降低冷空氣吹至冷凍室。)
MID	正常使用
MAX *2	· 當冷凍室不夠冷時。 (這是增加冷空氣吹至冷凍室。) · 當您想快速冷凍食物時。
Winter	冬天 (當環境溫度低於 10°C 時。)

*2: 由於此設定，冷藏室可能會不夠冷。
在此情況下，請確保將桿移至 MID。

請注意

溫度高於 10°C 時，請確保冷凍室的溫度不要設為「Winter」，因為會造成冷藏室的溫度不夠冷。
將旋鈕移至其他設定 (MAX-MIN)。

食品的儲存

將食品冷藏起來時，食品腐爛的速度就會減慢。
要延長易於腐爛食品的保存期限，就應當盡可能選擇較新鮮的食品。
下面為延長食品保存期限的簡要介紹，可供您參考。

水果／蔬菜

為盡量減少水份的流失，水果和蔬菜要用保鮮紙及膠袋輕輕包上（不封口），並將其放入蔬果保鮮室內。

乳製品和雞蛋

- 幾乎所有乳製品的包裝上都標有適當的保存溫度和保存期限。
- 請用箱內的蛋架保存蛋類。

肉類／魚／禽肉

- 請將其放在容器上，並包上保鮮紙。
- 若是大塊的肉、魚和禽肉，請將其放在層架的內側。
- 已經煮熟的食品務須用保鮮紙包好，或將其放在密封容器內。

* 新鮮食品注意事項：

- 新鮮食品（安全包裝）應在有限的時間內保存，以防止變質並嚴重影響其他保存的食物。

為達到最佳冷凍效果

- 食品質量應當新鮮。
- 若要快速冷凍食品，每次都必須少量放入。
- 食品應進行恰當密封，要封緊或蓋緊。
- 將食品均勻地放入冷凍室。
- 袋子和容器上要標上標示，並寫清楚冷凍食品的內容。

防止雪櫃內部結水珠或結霜的建議

- 請確保將食物放在層架上或架子裡。若食物掉下來，將無法關緊門。
- 高水分食品應放在密封容器內保存或密封保存。

請注意

- 為使冷氣充分循環，請將食品均勻地放在盤架上。
- 請將較熱的食品涼下來以後，才保存起來。如果將較熱的食品放進雪櫃，雪櫃內的溫度會升高，這樣往往很容易導致食品腐爛變質。
- 長時間打開門會導致雪櫃內的溫度顯著升高。
- 請勿讓食品和容器擋住使冷氣循環的出風口和吸入口。否則，食品就不能均勻地冷卻。

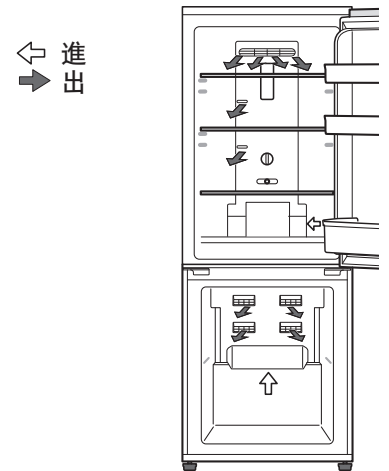

請勿直接將食品放在冷氣出風口旁。
這樣會引致食品凍結。

保養

重要提示

為防止雪櫃內板表面和塑膠部件發生開裂，請遵從如下操作提示。

- 食用油沾上塑膠部件時，請將之擦掉。
- 某些家用化學清潔劑可能會導致雪櫃損傷，因而只能使用稀釋過的廚房用清潔劑（肥皂水）。
- 如果使用未稀釋的清潔劑或者未徹底擦淨肥皂水，則有可能損壞雪櫃的塑膠部件。

清潔

- 拆下雪櫃門的層架和櫃門的儲存架。用溫水和廚房用清潔劑清洗，然後，用水洗清並使之乾透。
- 雪櫃內部要用浸泡在廚房用清潔劑的溫水裡的布塊擦洗。然後，用冷水將肥皂水徹底擦乾淨。
- 雪櫃的外殼沾上污漬時，請用柔軟的布塊擦洗。
- 雪櫃門封要用廚房用清潔劑的溫水和牙刷洗淨。

請注意

- 請勿使用強力清潔劑或溶劑（油漆、塗料、拋光粉、汽油、沸水等），否則可能導致雪櫃損傷。
- 一但拔出電源插頭，請等待至少 6 分鐘之後再重新接通電源。
- 在雪櫃內請勿使物體掉落，或用物體強烈碰撞內壁。否則可能導致內壁破裂。
- 從機櫃中取出玻璃層板時，確保不要掉落玻璃層板。

除霜

冷卻設備上的霜（從外面無法看到）會定期融化並流落至蒸發盤。之後，水被壓縮機的熱能乾燥。

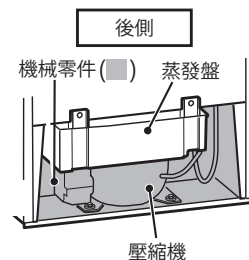

當冷藏室內燈損壞時

請聯繫 SHARP 認可的售後服務中心更換冷藏室內燈。非專業服務人員不得更換冷藏室內燈。

切斷雪櫃的電源時

如需將雪櫃長時間關閉，應遵循以下步驟以減少霉菌增長：

1. 將食物全部取出。
2. 將電源插頭從插座中拔出。
3. 將內部徹底清潔並乾淨。
4. 將雪櫃門打開數天並晾乾。

送修之前的初步檢查

送修之前，請對下列地方進行檢查。

問題	對策
雪櫃外箱有時會變熱。	這並非異常。防止結露的熱導管裝在機身的內部。
雪櫃發出噪聲時。	雪櫃如發出下述聲音，這並非異常。 <ul style="list-style-type: none"> · 運轉開始時，壓縮機發出較大的噪音 <ul style="list-style-type: none"> — — — 不久聲音會變小。 · 壓縮機每日一次發出較大噪音 <ul style="list-style-type: none"> — — — 緊隨自動除霜操作之後發出的運轉聲。 · 液體流動的聲音（咕嚕聲、嘶嘶聲） <ul style="list-style-type: none"> — — — 冷媒在管道內流動的聲音（聲音時而會變得較大）。 · 劈啪聲或吱嘎聲，吱吱聲 <ul style="list-style-type: none"> — — — 冷卻時內壁和內部零件膨脹和收縮的聲音。
當冷藏室不夠冷時。	<ul style="list-style-type: none"> · 冷凍室的溫度設定是否在夏天時設為「Winter」？ <ul style="list-style-type: none"> — — — 將冷凍桿移至其他設定。建議值為「MID」。
冷凍室不夠冷時。	<ul style="list-style-type: none"> · 冷藏室的溫度設定是否設在「MIN」側？ <ul style="list-style-type: none"> — — — 將雪櫃旋鈕移至「MAX」側。 · 冷凍室的溫度設定是否在冬天時設為「MID」？ <ul style="list-style-type: none"> — — — 將冷凍桿移至「Winter」側。
冷藏室的食物結凍。	<ul style="list-style-type: none"> · 冷藏室溫度調節旋鈕是否設定在 MAX 的狀態下？ <ul style="list-style-type: none"> — — — 將溫度調節設定改為其他設定。 · 若環境溫度低，即便雪櫃旋鈕設為「MIN」也可能將食物冷凍。 <ul style="list-style-type: none"> — — — 將冷凍桿移至「Winter」側。
雪櫃內部和雪櫃外側結霜或結露。	在下列情形下有可能發生這種現象。請用濕布擦掉霜，用乾布擦掉露珠。 <ul style="list-style-type: none"> · 周圍濕度較高時。 · 頻繁開關雪櫃門時。 · 雪櫃內存放水分較多的食品時。（請用保鮮紙包上）
冰塊是圓形的。	<ul style="list-style-type: none"> · 冰塊如果長時間保存可能會變圓。
當您關門時，造成其他門開啓。	<ul style="list-style-type: none"> · 由於風壓、食物量和地板狀況，門可能會打開。 <ul style="list-style-type: none"> — — — 若雪櫃門無法關閉，轉動調整腳以抬起雪櫃的前部。
地板是濕的。	<ul style="list-style-type: none"> · 檢查門密封墊是否損壞。若密封墊損壞，冷卻設備上的霜會比平時更厚，水可能會從蒸發盤中溢出。
雪櫃內部有異味。	<ul style="list-style-type: none"> · 請將氣味較強的食品用保鮮紙包起來。 · 脫臭裝置不能去掉所有異味。（僅適用於 SJ-BR18G）

送修之前的初步檢查

送修之前，請對下列地方進行檢查。

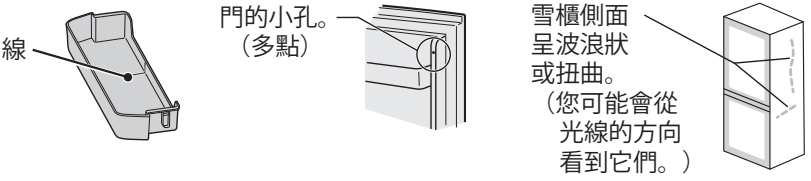
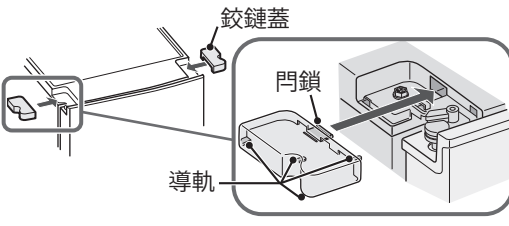
問題	對策
零件或內壁有線、孔洞和凹痕。	<p>• 下列項目不會是問題。這些是由於零件或產品生產過程造成。</p>  <p>線</p> <p>門的小孔。 (多點)</p> <p>雪櫃側面呈波浪狀或扭曲。 (您可能會從光線的方向看到它們。)</p>
雪櫃內的燈閃爍。	<p>• 它代表電氣零件故障。 務必請 SHARP 授權的服務中心進行維修。(無法停止冷卻運轉。但是內部冷卻過多或不足。)</p>
<ul style="list-style-type: none"> • 鉸鏈蓋安裝不牢固。 • 鉸鏈蓋脫落。 	<p>• 請務必按照下列說明進行安裝。 —— 依下列圖示推動鉸鏈蓋以安裝門鎖和導軌 (4 處)。</p>  <p>鉸鏈蓋</p> <p>門鎖</p> <p>導軌</p>

經檢查後仍需要送修時

請與就近的 SHARP 售後服務中心洽詢。

SHARP
SHARP CORPORATION