



微波爐

- 微波輸出功率：800W



R-S20CA(W)



R-S20CA(B)

燒烤微波爐

- 微波輸出功率：800W，
燒烤功率：1000W



R-G20CA(B)

使用說明書

本說明書包含重要資訊，請在使用微波爐前仔細閱讀。

重要事項：如未有按此說明書使用微波爐，或微波爐經改裝後在爐門開啟下運作，可能對健康構成嚴重威脅。



目錄

使用說明書

目錄.....	1
規格.....	1
微波爐及配件.....	2
控制板.....	3
重要安全須知.....	4-6
安裝事宜.....	6
微波強度.....	7
燒烤強度.....	7
微波及燒烤烹調.....	7
解凍指引.....	8
微波爐適用的器具.....	8
保養及清潔.....	9
問題解決.....	10



規格

型號名稱:	R-S20CA(B)/(W)	R-G20CA(B)
交流電壓	: 220V, 50 Hz	: 220V, 50 Hz
電力消耗: 微波烹調	: 1270瓦	: 1270瓦
輸出功率: 微波烹調	: 800瓦	: 800瓦
燒烤烹調	: -	: 1000瓦
待機模式(省電模式)	: 少於 1.0 瓦	: 少於 1.0 瓦
微波頻率	: 2450 MHz	: 2450 MHz
外部尺寸 (闊) x (高) x (深) 毫米	: 440 x 258 x 341	: 440 x 258 x 341
爐箱內尺寸(闊) x (高) x (深) 毫米*	: 306 x 208 x 307	: 306 x 208 x 307
容量	: 20 公升*	: 20 公升*
轉盤直徑	: \varnothing 255 毫米	: \varnothing 255 毫米
重量	: 約 11.0 公斤	: 約 11.5 公斤

* 微波爐內部容量是根據最大闊度、深度和高度而計算的。實際存放食品的容量較少。

備註: 設計及規格如有變更, 恕不另行通知。

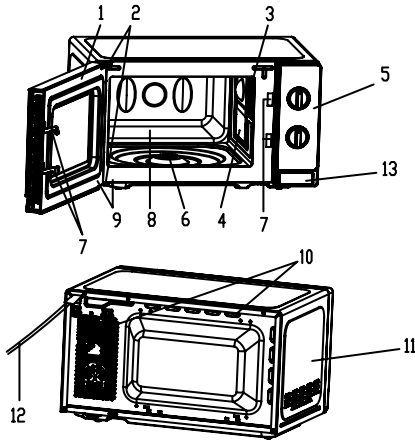

微波爐

1. 爐門
2. 門鉸
3. 照明燈
4. 波導管罩 (請不要拆出)
5. 控制面板
6. 轉盤電動軸
7. 門鎖
8. 爐箱
9. 爐門密封襯墊和襯墊表層
10. 通風口
11. 外箱
12. 電源線
13. 開門按鍵

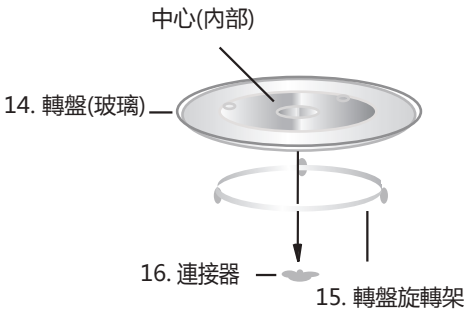

配件：

請檢查確定以下配件已齊備：

- (14) 轉盤 (15) 轉盤旋轉架 (16) 連接器 (17) 烤架
- 將轉盤旋轉架放在爐底中央，並可在連接器上任意旋轉。然後，將轉盤放在旋轉架上，讓它穩定在連接器上。
 - 為避免轉盤受損，在把食物和容器從爐內取出時，請確定不會觸及轉盤邊緣。



17. 烤架 (僅供R-G20CA(B)型号)

注意：當訂購配件時，請向SHARP客戶服務中心聯絡並提供兩項資料：配件名稱及型號名稱。

注意：

- 波導管罩容易損壞，當清潔微波爐內部時，請小心不要令它受損。
- 每次使用微波爐，必須把轉盤及旋轉架放好。這樣烹調時可更均勻。未放好的轉盤可能會發出聲響、旋轉不良，並可能損壞微波爐。
- 每次烹調時，所有食物和容器必須放在轉盤上。
- 轉盤可順時針或逆時針旋轉。您每次使用微波爐時，旋轉方向都可能不同。這不會影響烹調效果。
- 在每次烹調沒有加蓋的肥膩食物後，請徹底清潔爐內部，尤其是燒烤部件，它們都必須乾淨和沒有油脂。如油脂積聚，可能會引致過熱、出煙或起火。

⚠ 警告： ⚠ 此標籤表示本設備在使用期間，表面可能會熱燙。(僅適用於燒烤型號) 另外，在操作期間，爐門、外箱、爐內部、配件及盛碟，都會十分熱燙。為免燙傷，請使用厚身微波爐手套。



控制板

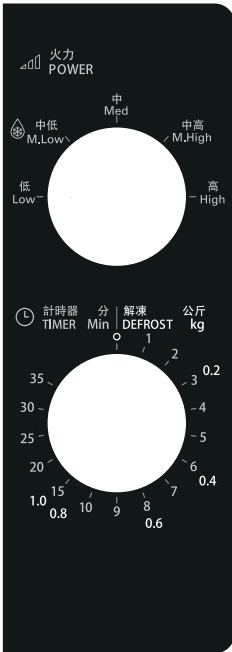

R-S20CA(B)/(W)

1. 微波火力控制旋鈕

火力強度

高=800 瓦

中高=620 瓦

中=440 瓦

中低=260 瓦

低=130 瓦

2. 計時器 / 解凍旋鈕 (0-35 分鐘 / 0.2- 1.0 公斤)

計時器 / 解凍旋鈕有兩組級別。

外圈級別是按公斤重量進行解凍。

內圈級別用於設定時間。

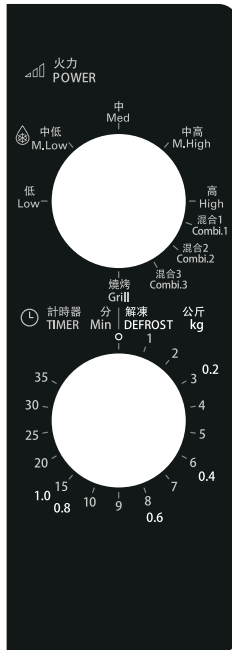

R-G20CA(B)

1. 微波火力控制旋鈕

火力強度

高=800 瓦

中高=620 瓦

中=440 瓦

中低=260 瓦

低=130 瓦

組合1 = 80% 燒烤 20% 微波煮食

組合2 = 70% 燒烤 30% 微波煮食

組合3 = 60% 燒烤 40% 微波煮食

燒烤 = 100% 燒烤

2. 計時器 / 解凍旋鈕 (0-35 分鐘 / 0.2- 1.0 公斤)

計時器 / 解凍旋鈕有兩組級別。

外圈級別是按公斤重量進行解凍。

內圈級別用於設定時間。



請細心閱讀重要安全須知，並保留作將來參考之用。

為防失火危險：

在微波爐操作期間，應小心看管。如所選微波強度太強，或烹調時間過長，均有可能過熱而起火。

- 本微波爐設計僅限於在桌面上使用，請勿放在廚櫃內。
- 電源插口必須隨時可以觸及，以便緊急時易於拔除插頭。交流電源必須為 220 伏特，50Hz，並備有最少 10A 配電線路熔斷器，或最少 10A 配電斷路器。
- 請為此設備提供專用獨立電源。
- 請勿將微波爐放於熱源位置，如傳統焗爐附近。
- 請勿將微波爐安裝於濕度高或濕氣積聚的位置。
- 請勿在戶外存放或使用本微波爐。

如微波爐冒煙，請關掉及拔除微波爐電源，並保持爐門關閉，以遏止任何可能出現的火焰。

只可使用適用於微波爐的容器及用具，詳情請參閱 C-8 頁。此外，用具應經過檢查，以確定它們適用於微波爐。

在烹調以塑膠或紙盛載的食物時，請留意微波爐的情況，以免起火。

在使用後，請清潔波導管罩、爐壁、轉盤及轉盤旋轉架。以確保乾爽及沒有油脂。如油脂積累，可能會導致過熱，並冒煙或起火。

- 請勿在微波爐附近或通風口放置易燃物品。
- 請勿遮擋通風口。
- 請移除食物及其包裝上的所有金屬封口及線圈等。在金屬表面形成的電弧可能會起火。
- 請勿使用微波爐加熱食油以作油炸烹調。食油的溫度會不受控制並可能燃燒。
- 如欲烹調爆谷，必須使用供微波爐專用的爆谷專用袋子。
- 請勿在微波爐內儲存食物或任何其他物品。
- 在啟動微波爐後，請檢查有關設定以確保其操作符合要求。
- 為避免過熱及起火，在烹調或加熱高糖份或肥膩食物，如香腸卷、餡餅或聖誕布甸時，請特別小心處理。

為避免導致受傷的情況：

警告：

如微波爐已損毀或操作異常，請勿使用。

在使用前，請檢查以下事項：

- 爐門：請確定爐門已關妥，並沒有對位不齊或變形。
- 門鉸及安全門鎖：檢查以確定沒有損壞或鬆脫。
- 爐門密封襯墊和襯墊表層：確定沒有受損。
- 爐內壁或爐門上：確定沒有損毀。
- 電源線及插頭：確定沒有損毀。

如爐門或密封襯墊受損，在由 SHARP 授權的技術人員修理妥當之前，請勿使用。

請勿自行調校、修理或修改微波爐。除了 SHARP 授權的維修技術人員外，任何人試圖拆除防止微波能量暴露的外殼，進行任何修理或維修，都十分危險。

- 請勿在爐門開啟的情況下使用微波爐，或以任何方式修改門鎖。
- 如在爐門密封襯墊和襯墊表層之間附有物件，請勿使用微波爐。

請勿讓油脂或塵埃在爐門密封襯墊及其相連部份積聚。請定時清潔本微波爐，並清除任何殘留食物。請參閱 C-9 頁的“保養及清潔”說明。如未有保持微波爐清潔，可能會損害其表面，導致設備壽命縮短，並可能引起危險。

- 配有心臟起搏器的人士，請諮詢醫生或該器材的製造商，以了解有關使用微波爐的注意事項。

為避免可能導致觸電的情況：

- 在任何情況之下，亦不應拆除外箱。
- 請勿跌入或插入任何物件於門鎖口或通風口。如有不慎跌入物件，請立即拔除電源，並聯絡 SHARP 客戶服務中心跟進。
- 請勿把電源線或插頭浸在水或任何其他液體中。
- 請勿讓電源線掛在桌子或檯面邊緣。



重要安全須知

- 請保持電源線遠離熱燙表面，包括微波爐後。
- 請勿試圖自行更換爐燈，或讓任何不屬SHARP授權的技術人員進行有關工作。如爐燈失效，請諮詢您的經銷商或SHARP維修中心。
- 如本設備的電源線受損，必須以專用電線更換。
- 有關更換工作必須由SHARP客戶服務中心進行。

為避免導致爆炸及爆沸的情況：

警告：液體及其他食物絕不可在密封容器內加熱，以免有爆炸的情況發生。如加熱飲品，有可能導致延後爆沸，因此在處理有關容器時必須特別小心。

- 切勿使用密封容器。在使用前，必須先移除封條及蓋子。即使在微波爐關掉後，密封容器仍有可能因為壓力的累積而爆炸。
- 在微波加熱液體時，必須特別小心。請使用闊口容器，讓氣泡可排走。

切勿使用窄口容器加熱液體，如嬰兒奶瓶，因為在加熱時，容器內的液體可能會噴出導致燙傷。

- 為免滾熱液體爆沸及可能導致燙傷：
 1. 請勿烹調過長時間。
 2. 在加熱/翻熱前攪拌液體。
 3. 在翻熱時，建議加入玻璃棒或類似工具（非金屬）。
 4. 在烹調完成後，讓液體靜止最少 20 秒，以防延後爆沸。

請勿以微波爐烹調連殼生雞蛋，連殼熟雞蛋亦不應以微波爐加熱，因為它們有可能爆炸，即使在烹調完成後。如需烹調或翻熱未經炒煮或混合的雞蛋，請刺穿蛋黃及蛋白，否則雞蛋可能會爆炸。在以微波爐翻熱熟雞蛋前，請去殼並切片。

- 在烹調薯仔、香腸及水果時，請刺穿其表皮，否則它們可能會爆炸。

為避免導致燙傷的情況：

警告：嬰兒奶瓶及食物樽內食物，在進食前必須攪拌或搖晃，並檢查其溫度，以避免燙傷。

- 從微波爐拿取食物時，請使用鍋墊或焗爐手套，以避免燙傷。

- 使用容器、爆谷食材、焗爐袋時，請必須打開，並遠離面孔及手部，以免被蒸汽及爆沸燙傷。

為免燙傷，在食用前請時常測試食物溫度，並加以攪拌；如為嬰兒、兒童及老人提供食物，更要特別小心。可接觸的爐身部分在使用時可能會變得熱燙，請勿讓兒童接近。

- 容器的溫度未必能真正代表食物或飲品的溫度，因此每次都必須檢查食物或飲品的溫度。
- 每次打開爐門時，都要盡量遠離，以免受溢出的蒸氣和熱力燙傷。
- 在加熱填充烤焗食物後，請切片以釋放蒸氣並避免燙傷。
- 此設備不應使用外置計時器或遙控系统操作。
- 兒童請遠離門板，以免被燒傷。

為避免兒童誤用：

警告：請先為兒童提供充分指導，讓他們能夠安全使用本微波爐，並明白不當使用的危險後，方可讓兒童在沒有監督下使用。本設備並不是為身體、感官或心理有缺憾，或缺乏相關經驗或知識的人士（包括兒童）而設計，除非他們在能夠負責其安全的人監督，或已接受其操作指示的情況下使用。兒童應受到監管，以免他們玩弄此電器。

- 請勿靠倚在爐門上或將爐門來回搖晃。
- 請勿視此微波爐為玩具或以此嬉戲。
- 請教導兒童認識所有重要安全說明：使用鍋墊、小心移除食物蓋子，特別注意令食物鬆脆的包裝（如：發熱物料），它們可能特別熱燙。

其他警告：

- 切勿以任何方式改動微波爐。
- 當微波爐正在操作，請勿移動。
- 此微波爐僅適用於家居環境，並僅可作烹調食物。不適合商業或實驗室用途。



為安心使用本產品並避免損壞：

- 切勿在微波爐內空無一物時進行操作。當使用烤架或發熱材料時，請經常在它們下面放置耐熱隔層，如陶瓷碟，以免因熱壓而損壞轉盤及旋轉架。預熱時間切勿超過菜式的指示。
- 請勿使用金屬用具，它們會反射微波，可能會造成電弧現象。請勿把罐頭放進微波爐。
- 請使用專為本微波爐而設計的轉盤和旋轉架。請勿在沒有轉盤的情況下使用本微波爐。

為免轉盤破裂：

- (a) 在以水清洗轉盤前，請讓轉盤冷卻。
 - (b) 請勿放置熱食物或用具在冷轉盤上。
 - (c) 請勿放置冷食物或用具在熱轉盤上。
- 在微波爐操作時，請勿放置任何物件在外箱上。

注意：

如您不肯定如何連接您的微波爐，請諮詢合格電工。

如因未能瞭解正確的電力連接程序，而造成微波爐損壞或個人損傷，製造商及經銷商概不負責。

爐壁或爐門密封襯墊和襯墊表層上，間中可能有水氣或水點凝結。這些都屬正常現象，並不表示有微波洩漏或操作異常。



此標籤表示本設備在使用期間，表面可能會熱燙。

安裝事宜



1. 從微波爐內部移除所有包裝物料。
2. 仔細檢查微波爐是否有任何損壞跡象。
3. 將微波爐放在穩固的平面上，該位置應可負荷爐身加上烹調最重食物時的總重量。請勿將微波爐放在廚櫃中。
4. 選擇一個可提供足夠空間予進氣及/或散氣的平面，設備後方應面向牆壁。
 - 微波爐和鄰近牆壁之間的空間，最少有20厘米。
 - 在微波爐上方留下最少30厘米的空間。
 - 爐底應距離地面85厘米或以上。
 - 請勿除去微波爐底部的爐腳。
 - 如阻擋出及/或入的通風口，可能會損壞微波爐。
 - 請把微波爐放在遠離收音機和電視的位置，微波爐操作期間可能會影響電台或電視的接收。
5. 穩妥地連接微波爐的插頭到標準家居電源插座。

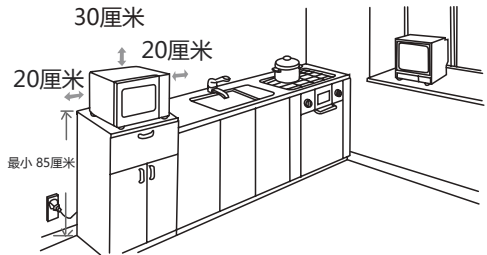

警告：

- 請勿把微波爐放置在會產生熱力、潮濕或高濕度的地方(例如傳統焗爐附近或上面)或接近易燃物料(如布料家具)。
- 請勿阻擋或阻塞散氣口。
- 請勿在爐頂放置物品。



微波強度

本微波爐備有5個微波火力強度，可供選擇，如下所列。

微波強度根據微波能量開啟和關閉而有所不同。當使用高火力以外的設定時，在煮食或解凍期間您可聽到微波能量開關的聲音。

一般而言，我們建議以下火力煮食：

高=800 瓦 用於快速烹調，或翻熱食物。如砂鍋食物、飲料及蔬菜等。

中高=620瓦 用於較長時間的烹調，如烤肉排、肉條及碟盤食物等，亦可用烹調熱度較敏感的食物，如海綿蛋糕。在此較低強度的設定下，食物的烹調會較均勻，不會令食物邊緣位置過熱。

中=440 瓦 用於密度較高的食物，它們在傳統烹調時需要較長時間，如牛肉砂鍋。如欲確保肉質鮮嫩，建議使用此設定。

中低=260 瓦 用於解凍，選擇此設定可確保食物解凍效果均勻。此設定亦適用於煮飯、意粉、餃子及蛋撻。

低=130 瓦 用於慢速解凍，如忌廉蛋糕或糕餅。

注意：當從爐中取出食物時，請確保微波爐電源已關閉，請將計時器控制轉至0（零）位置。否則，在沒有放進食物而操作微波爐時，可能會導致過熱而損壞磁電管。



燒烤強度 (僅供R-G20CA(B)型号)

本微波爐備有4個燒烤火力強度，可供選擇，如下所列。

功能/火力	火力	應用
組合1	80%燒烤 20%微波煮食	香腸、羊肉、肉串、海鮮、牛排
組合2	70%燒烤 30%微波煮食	雞塊、雞胸肉、豬排
組合3	60%燒烤 40%微波煮食	全雞
燒烤	100%燒烤	烤麵包，切片食物

注意：當從爐中取出食物時，請確保微波爐電源已關閉，請將計時器控制轉至0（零）位置。否則，在沒有放進食物而操作微波爐時，可能會導致過熱而損壞磁電管。



微波及燒烤烹調

1. 準備並將食物放在一個合適的容器中（請參見C-8頁「微波爐適用的器具」），把食物或容器直接放到轉盤的中間位置，關上爐門。
2. 將**火力控制**旋鈕轉到需要的設定 5個微波及4個燒烤火力強度。
3. 將**計時器 / 解凍控制**旋鈕轉到需要煮食 / 解凍的時間，微波爐即會自動開始運作。
4. 當煮食 / 解凍完成後，**計時器 / 解凍控制**旋鈕會回到「0」位置並有響聲提示。微波爐燈將自動關閉，轉盤亦將停止轉動。打開微波爐門，小心取出食物/容器。如有需要，可把食物靜置一會。

煮食提示：

當微波爐啟動後，微波爐燈將亮起，轉盤將順時針或逆時針旋轉。

如果您想在設定的煮食時間前停止煮食，請將**計時器 / 解凍控制**旋鈕轉動至「0」（關閉），或打開爐門。在煮食過程中可以隨時打開爐門，要繼續煮食，請關上爐門。如果在煮食過程中您想更改烹調時間，只需將**計時器 / 解凍控制**旋鈕轉動至新設定。

當煮食 / 解凍的時間少於 3分鐘，請將**計時器 / 解凍控制**旋鈕轉動超越10分鐘位置，然後再轉動至所需要的設定。這樣計時器便可以運行得更準確。

在煮食過程中如要改變火力強度，請將微波火力控制旋鈕轉到所要的設定。

注意：

確保在煮食結束後，計時器 / 解凍控制旋鈕已返回到「0」位置，否則當微波爐門關上時，微波爐將會自動啟動。

解凍指引



此解凍指引使某些食物解凍時更為容易。

此微波爐可用於解凍以下食物：

雞塊、肉排、魚（整條或魚片），免治肉和香腸。

例子：解凍0.4公斤的雞塊：

1. 將雞塊放在轉盤，再將轉盤放入微波爐。
2. 將微波火力控制旋鈕轉至解凍設定（中低）。
3. 將解凍旋鈕轉到 0.4 公斤的設定。微波爐將立即啟動。在解凍期間將雞塊翻轉1-2次。
4. 在解凍後，把食品蓋上錫紙，擺放至完全解凍。

注意：解凍時間是按標準情況下計算的。請檢查解凍情況，如有需要，可調整解凍時間。

微波爐適用的器具



以微波爐烹調/解凍食物，必須讓微波能量穿過容器滲透到食物中，所以挑選是非常重要的。

圓形/橢圓形的碟盤比方形/長形較為合適，因為置於角落的食物會較易過熱。以下一系列均為適用的器皿。

器皿	微波安全	備註
錫紙/錫紙盤	✓ / ✗	小塊的錫紙可用以遮蓋食物防止過熱。保持錫紙離爐身最少2厘米，因錫紙可能產生電弧。並不建議使用錫紙盤，除非製造商註明用法，並請小心遵照指示使用。
微波盤	✓	必須遵照製造商指示。請勿超過註明的加熱時間，並請非常小心。此類容器可能會非常燙熱。
瓷器及陶瓷	✓ / ✗	瓷器，陶器，釉面陶器和骨瓷器都通常適用，如帶有金屬花紋除外。
玻璃器皿	✓	使用精巧的玻璃器皿須特別小心，如突然加熱可導致碎裂。
金屬	✗	不建議使用金屬器具，因可能產生電弧，並導致起火。
塑膠/聚苯乙烯（快餐盒）	✓	必須小心使用，因部分此類容器會在高溫下變形、溶化或脫色。
保鮮紙	✓	不可接觸食物，並必須刺孔讓蒸汽排出。
冰櫃/燒烤袋	✓	必須刺孔讓蒸汽排出，並請確保它們適合微波使用。
紙碟、紙杯、廚房紙	✓	請勿使用塑膠或金屬綁帶，因它們可能在金屬產生電弧時溶化或著火。
吸管及木製容器	✓	只可於加熱時使用或用以吸收水份。必須小心使用，以防過熱著火。
再造紙及報紙	✗	使用這些物料時必須時刻留意微波爐，以防過熱著火。或可能含有金屬物質，因而產生電弧並著火

⚠ 警告：

當以塑膠或紙類容器加熱食物，請密切注意微波爐以防著火。



保養及清潔

小心：請勿使用現成潔爐劑、蒸汽清潔機、磨砂清潔劑、過強的清潔劑、或任何含有氫氧化鈉或磨擦表層的潔具清潔微波爐的任何部分。

定期清潔微波爐，並清除任何殘餘食物。確保微波爐清潔，否則微波爐表面可能損壞，並會縮短此電器的壽命，甚至導致危險情況。

微波爐外部

微波爐的外部可輕易以溫和的梘液和清水清潔。請確保梘液以濕布抹淨，並以柔軟的毛巾抹乾微波爐外部。

控制板

清潔前先打開爐門，以暫停控制板操作。清潔控制板必須格外小心。使用只有清水的濕布輕輕拭抹控制板直至潔淨。避免使用過量清水。切勿使用任何化學物或磨砂清潔劑。

注意：

請注意在清潔過程中不要把旋鈕扭到"0"以外的位置，否則關上爐門後會自動運作。

微波爐內部

1. 一般清潔，只需在每次用完當微波爐仍微暖時，以柔軟的濕布或海綿抹淨濺出的食物。如濺出的食物較多，使用溫和的梘液以濕布拭抹至清除所有食物殘渣。切勿拆出波導管罩。

2. 請確保梘液或清水沒有滲進爐壁的小孔，以免導致微波爐損壞。

3. 切勿使用噴霧式清潔劑清潔微波爐內部。永遠保持波導管罩清潔。

波導管罩的物料比較脆弱，必須小心清潔（請遵照以上清潔指引）。

注意：過份浸透或導致波導管罩分解。

波導管罩屬消耗部件，如缺乏定期清潔或需更換。

轉盤及轉盤旋轉架

把轉盤及轉盤旋轉架從微波爐拆出。

以溫和的清潔液加水清洗轉盤及轉盤旋轉架。轉盤及轉盤旋轉架均可使用洗碗碟機清洗。

爐門

要清除所有污垢，請定期以柔軟的濕布清潔爐門兩面、爐門封邊及附近部分。切勿使用磨砂清潔劑。

注意：請勿使用蒸汽清潔機。

清潔小秘訣 – 想更輕易清潔微波爐：

把半個檸檬放進碗內，加入 300 毫升 (1/2 品脫) 清水，加熱 10 至 12 分鐘。使用柔軟的乾布抹淨微波爐。



確保電源線遠離受熱表面。如懷疑微波爐並非運作正常，在聯絡技術人員前您可先自行進行數項簡單檢查。

按以下步驟進行簡單檢查：把半杯水置於轉盤並烹調 1 分鐘。

1. 烹調期間爐內照明燈是否亮起？
2. 轉盤有否轉動？
3. 散熱風扇是否運作？(請把手放於通風口上檢查。)
4. 在 1 分鐘後有否聽到響聲？
5. 杯中的水是否熱燙？
6. 在 3 分鐘後燒烤熱管有否變紅？

如果就以上任何問題您的答案是「否」，請先檢查微波爐是否正確插上電源並且保險絲正常運作。如果兩者皆沒有問題，請查看以下問題解決列表。

警告：切勿自行調校、修理或改裝微波爐。除 SHARP 授權的技術人員以外，任何人等進行服務提供或維修均屬非常危險。這是非常重要的，因為過程可能涉及移除防止微波能量外洩的保護蓋。

- 爐門封邊可在微波爐操作期間防止微波外洩，但並非密封式封存。如在爐門發現水滴、光線或微暖均屬正常現象。水份較高的食物會釋放蒸汽並在爐門內導致凝聚，因而從微波爐滴下水點。
- **維修及改裝：**當微波爐不能正常運作，請勿試圖進行操作。
- **外爐身及照明燈開蓋：**切勿拆開爐外箱。這將非常危險，因為或會觸及爐內絕對不能觸及的高壓部分，嚴重者可致命。您的微波爐並不具備照明燈開蓋設計。如果照明燈損壞，請切勿試圖自行更換，而應聯絡 SHARP 維修中心。

問題解決列表

疑問	答案
空氣圍繞爐門流動。	微波爐在操作時，空氣會在內部流通。由於爐門並非密封式設計，所以空氣或會從爐門漏出。
爐內有水份凝聚，並可能從爐門滴下。	微波爐內部溫度一般會比正烹調的食物較低，所以在烹調過程中可能會出現蒸汽，並在較冷的表面凝聚。蒸汽的份量視乎正烹調的食物水份含量而定。個別食物如薯仔水份含量會較高。積聚在爐門玻璃的凝聚水份在數小時後應會散去。
烹調期間爐內出現閃光或產生電弧。	在烹調期間，當金屬物體離爐壁太近，將可能出現電弧的情況。這或會刮到爐壁，但不會損壞微波爐。
薯仔產生電弧	請確保薯仔上的所有薯眼均已切掉，並且在薯仔上刺洞。把薯仔直接置於轉盤或耐熱容器。
顯示屏亮起但控制面板按鍵沒有反應。	檢查爐門是否正常關閉。
微波爐烹調太慢。	確定選用正確微波強度。
微波爐發出噪音。	在烹調/解凍期間，微波能量會間歇脈動。
外爐身變熱。	觸碰外爐身有機會感覺暖熱，請勿讓兒童靠近。

SHARP

Important



MICROWAVE OVEN

➤ MW : 800W



R-S20CA(W)



R-S20CA(B)

MICROWAVE OVEN WITH GRILL

➤ MW : 800W, Grill : 1000W



R-G20CA(B)

ENGLISH

OPERATION MANUAL

This operation manual contains important information which you should read carefully before using your microwave oven.

IMPORTANT: There may be a serious risk to health if this operation manual is not followed or if the oven is modified so that it operates with the door open.



CONTENTS

OPERATION MANUAL

CONTENTS.....	1
SPECIFICATIONS.....	1
OVEN AND ACCESSORIES	2
CONTROL PANEL.....	3
IMPORTANT SAFETY INSTRUCTIONS.....	4-6
INSTALLATION.....	6
MICROWAVE POWER LEVELS.....	7
GRILL POWER LEVELS.....	7
MICROWAVE AND GRILL COOKING.....	7
DEFROSTING GUIDE	8
SUITABLE OVENWARE	8
CARE AND CLEANING	9
TROUBLESHOOTING.....	10



SPECIFICATIONS

Model name:	R-S20CA(B)/(W)	R-G20CA(B)
AC Line Voltage	: 220 V, 50 Hz	: 220 V, 50 Hz
AC Power required: Microwave	: 1270 W	: 1270 W
Output power: Microwave	: 800 W	: 800 W
Grill	: -	: 1000 W
Off Mode (Energy Save Mode)	: less than 1.0 W	: less than 1.0 W
Microwave Frequency	: 2450 MHz	: 2450 MHz
Outside Dimensions (W) x (H) x (D) mm	: 440 x 258 x 341	: 440 x 258 x 341
Cavity Dimensions (W) x (H) x (D) mm	: 306 x 208 x 307	: 306 x 208 x 307
Oven Capacity	: 20 litres*	: 20 litres*
Turntable	: ø 255 mm	: ø 255 mm
Weight	: approx. 11.0 kg	: approx. 11.5 kg

* Internal capacity is calculated by measuring maximum width, depth and height. Actual capacity for holding food is less.

DESIGN AND SPECIFICATIONS ARE SUBJECT TO CHANGE WITHOUT PRIOR NOTICE

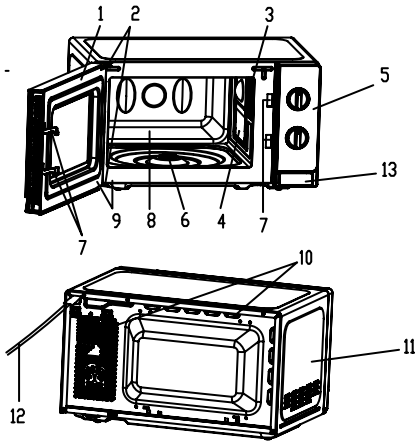

OVEN

1. Door
2. Door hinges
3. Oven lamp
4. Waveguide cover (DO NOT REMOVE)
5. Control panel
6. Turntable motor shaft
7. Door safety latches
8. Oven cavity
9. Door seals and sealing surfaces
10. Ventilation openings
11. Outer cabinet
12. Power supply cord
13. Door opening button

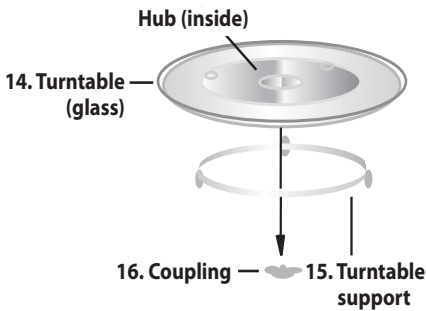

ACCESSORIES:

Check to make sure the following accessories are provided:

- (14) Turntable (15) Turntable support (16) Coupling (17) Rack

Place the turntable support in the centre of the oven floor so that it can freely rotate around the coupling. Then place the turntable on to the turntable support so that it locates firmly into the coupling.

To avoid turntable damage, ensure dishes and containers are lifted clear of the turntable rim when removing them from the oven.

NOTE: When you order accessories, please mention two items: part name and model name to your dealer or SHARP authorised service agent.



17. Rack (only for R-G20CA(B))

NOTES:

- The waveguide cover is fragile. Care should be taken when cleaning inside the oven to ensure that it is not damaged.
- Always operate the oven with the turntable and turntable support fitted correctly. This promotes thorough, even cooking. A badly fitted turntable may rattle, may not rotate properly and could cause damage to the oven.
- All food and containers of food are always placed on the turntable for cooking.
- The turntable rotates clockwise or anti-clockwise. The rotary direction may change each time you start the oven. This does not affect cooking performance.
- After cooking fatty foods without a cover, always clean the cavity and especially the grill heating element thoroughly, these must be dry and free from grease. Built-up grease may overheat and begin to smoke or catch fire.

⚠ WARNING: ⚠ This symbol means that the surfaces are liable to get hot during use. (only for grill model). The door, outer cabinet, oven cavity, accessories and dishes will become very hot during operation. To prevent burns, always use thick oven gloves.



CONTROL PANEL

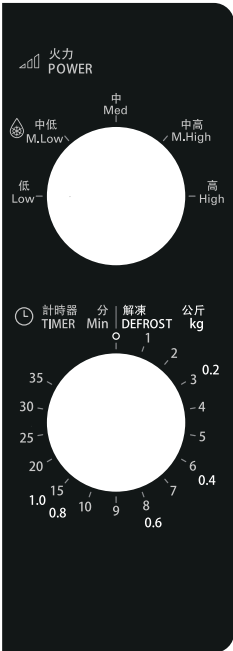

R-S20CA(B)/(W)

1. MICROWAVE POWER CONTROL knob

Power level

High=800 WATT

M.High=620 WATT

Med=440 WATT

 **M.Low**=260 WATT

Low=130 WATT

2. TIMER/ DEFROST GUIDE knob (0-35 Mins/ 0.2 – 1.0 kg)

The TIMER/ DEFROST GUIDE features two scales. The outer scale is for defrosting according to weight in kg. The inner scale is used for setting the time.

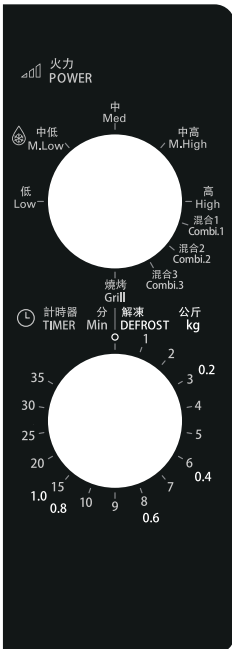

R-G20CA(B)

1. MICROWAVE POWER CONTROL knob

Power level

High=800 WATT

M.High=620 WATT

Med=440 WATT

 **M.Low**=260 WATT

Low=130 WATT

Grill

Combi.1 = 80% grill 20% micro.

Combi.2 = 70% grill 30% micro.

Combi.3 = 60% grill 40% micro.

Grill = 100% grill

2. TIMER/ DEFROST GUIDE knob (0-35 Mins/ 0.2 – 1.0 kg)

The TIMER/ DEFROST GUIDE features two scales. The outer scale is for defrosting according to weight in kg. The inner scale is used for setting the time.

IMPORTANT SAFETY INSTRUCTIONS



IMPORTANT SAFETY INSTRUCTIONS: READ CAREFULLY AND KEEP FOR FUTURE REFERENCE

To avoid the risk of fire:

The microwave oven should not be left unattended during operation. Power levels that are too high, or cooking times that are too long, may overheat foods resulting in a fire.

- This oven is designed to be used on a countertop only. It is not designed to be built into a kitchen unit. Do not place the oven in a cabinet.
- The electrical outlet must be readily accessible so that the unit can be unplugged easily in an emergency. The AC power supply must be 220 V, 50 Hz, with a minimum 10 A distribution line fuse, or a minimum 10 A distribution circuit breaker.
- A separate circuit serving only this appliance should be provided.
- Do not place the oven in areas where heat is generated. For example, close to a conventional oven.
- Do not install the oven in an area of high humidity or where moisture may collect.
- Do not store or use the oven outdoors.

If smoke is observed, switch off or unplug the oven and keep the door closed in order to stifle any flames.

Use only microwave-safe containers and utensils. See Page E-8. Utensils should be checked to ensure that they are suitable for use in microwave ovens.

When heating food in plastic or paper containers, keep an eye on the oven for signs of smoke or burning.

Clean the waveguide cover, the oven cavity, the turntable and turntable support after use.

These must be dry and free from grease.

Built-up grease may overheat and begin to smoke or catch fire

- Do not place flammable materials near the oven or ventilation openings.
- Do not block the ventilation openings.
- Remove all metallic seals, wire twists, etc., from food and food packages. Arcing on metallic surfaces may cause a fire.
- Do not use the microwave oven to heat oil for deep frying. The temperature cannot be controlled and the oil may catch fire.
- To make popcorn, use only special microwave popcorn makers.
- Do not store food or any other items inside the oven.
- Check the settings after you start the oven to ensure the oven is operating as desired.
- To avoid overheating and fire, special care must be taken when cooking or reheating foods with a high sugar or fat content, for example, Sausage rolls, Pies or Christmas pudding.

To avoid the risk of injury:

WARNING:

Do not operate the oven if it is damaged or malfunctioning. Check the following before use:

- a) The door; make sure the door closes properly and ensure it is not misaligned or warped.
- b) The hinges and safety door latches; check to make sure they are not broken or lost.
- c) The door seals and sealing surfaces; ensure that they have not been damaged.
- d) Inside the oven cavity or on the door; make sure there are no dents.
- e) The power supply cord and plug; ensure that they are not damaged.

If the door or door seals are damaged, the oven must not be operated until it has been repaired by a qualified service technician authorised by SHARP.

Never adjust, repair or modify the oven yourself. It is hazardous for anyone other than a qualified service technician authorised by SHARP to carry out any service or repair operation which involves the removal of a cover which gives protection against exposure to microwave energy.

- Do not operate the oven with the door open or alter the door safety latches in any way.
- Do not operate the oven if there is an object between the door seals and sealing surfaces.

Do not allow grease or dirt to build up on the door seals and adjacent parts. Clean the oven at regular intervals and remove any food deposits. Follow the instructions for "Care and Cleaning" on page E-9. Failure to maintain the oven in a clean condition could lead to a deterioration of the surface that could adversely affect the life of the appliance and possibly result in a hazardous situation.

- Individuals with PACEMAKERS should check with their doctor or the manufacturer of the pacemaker for precautions regarding microwave ovens.

To avoid the risk of electric shock:

- Do not remove the outer cabinet.
- Never spill or insert any objects into the door lock openings or ventilation openings. In the event of a spill, turn off and unplug the oven immediately, and call an authorised SHARP service agent.
- Do not immerse the power supply cord or plug in water or any other liquid.
- Do not let the power supply cord hang over the edge of a table or work surface.



IMPORTANT SAFETY INSTRUCTIONS

- Keep the power supply cord away from heated surfaces, including the rear of the oven.
- Do not attempt to replace the oven lamp yourself or allow anyone who is not an electrician authorised by SHARP to do so. If the oven lamp fails, please consult your dealer or an authorised SHARP service agent.
- If the power supply cord of this appliance is damaged, it must be replaced with a special cord.
- The exchange must be made by an authorised SHARP service agent.

To avoid the risk of explosion and sudden boiling:

WARNING: Liquids and other foods must not be heated in sealed containers to avoid the risk of explosion.

Microwave heating of beverages can result in delayed eruptive boiling, therefore care must be taken when handling the container.

- Never use sealed containers. Remove seals and lids before use. Sealed containers can explode due to a build up of pressure even after the oven has been turned off.
- Pay attention when microwaving liquids. Use a wide mouthed container to allow bubbles to escape.

Never heat liquids in narrow necked containers such as baby bottles, as this may result in eruption of the contents from the container when heated and cause burns.

- To prevent sudden eruption of boiling liquid and possible scalding:
 1. Do not use excessive cooking of time.
 2. Stir liquid prior to heating/reheating.
 3. Insert a glass rod or similar utensil(not metal) into the liquid whilst reheating.
 4. Let liquid stand for at least 20 seconds in the oven at the end of cooking time to prevent delayed eruptive boiling.

Do not cook eggs in their shells, and whole hard boiled eggs should not be heated in microwave ovens since they may explode even after microwave cooking has ended. To cook or reheat eggs which have not been scrambled or mixed, pierce the yolks and the whites, or the eggs may explode. Shell and slice hard boiled eggs before reheating them in the microwave oven.

- Pierce the skin of such foods as potatoes, sausages and fruit before cooking, or they may explode.

To avoid the risk of burns:

WARNING: The contents of feeding bottles and baby food jars must be stirred or shaken and the temperature checked before consumption in order to avoid burns.

- Use pot holders or oven gloves when removing food from the oven to prevent burns.

- Always open containers, popcorn makers, oven cooking bags, etc., away from the face and hands to avoid steam burns and eruption of boiling.

To avoid burns, always test food temperature and stir before serving and pay special attention to the temperature of food and drink given to babies, children or the elderly. Accessible parts may become hot during use. Young children should be kept away.

- The temperature of the container is not always a true indication of the temperature of the food or drink; always check the food or drink temperature.
- Always stand back from the oven door when opening it to avoid burns from escaping steam and heat.
- Slice stuffed baked foods after heating to release steam and avoid burns.
- Keep children away from the door to prevent them from burning themselves.
- External timer or remote control system operation can't be applied in this unit.

To avoid misuse by children:

WARNING: Only allow children to use the oven without supervision when adequate instructions have been given so that the child is able to use the oven in a safe way and understands the hazards of improper use. This appliance is not intended for use by persons (including children) with reduced physical, sensory or mental capabilities, or lack of experience and knowledge, unless they have been given supervision or instruction concerning use of the appliance by a person responsible for their safety. Children should be supervised to ensure that they do not play with the appliance.

- Do not lean or swing on the oven door.
- Do not play with the oven or use it as a toy.
- Children should be taught all important safety instructions: use of pot holders, careful removal of food coverings; paying special attention to packaging (e.g. self-heating materials) designed to make food crisp, as they may be extra hot.

Other warnings:

- Never modify the oven in any way.
- Do not move the oven while it is in operation.
- This oven is for home food preparation only and may only be used for cooking food. It is not suitable for commercial or laboratory use.

IMPORTANT SAFETY INSTRUCTIONS



To ensure trouble-free use of your oven and avoid damage.

- Never operate the oven when it is empty. When using a browning dish or self-heating material, always place a heat-resistant insulator such as a porcelain plate under it to prevent damage to the turntable and turntable support due to heat stress. The preheating time specified in the dishes instructions must not be exceeded.
- Do not use metal utensils, which reflect microwaves and may cause electrical arcing. Do not put cans in the oven.
- Use only the turntable and the turntable support designed for this oven. Do not operate the oven without the turntable.

To prevent the turntable from breaking:

- (a) Before cleaning the turntable with water, leave the turntable to cool.
 - (b) Do not put hot foods or hot utensils on a cold turntable.
 - (c) Do not put cold foods or cold utensils on a hot turntable.
- Do not place anything on the outer cabinet during operation.

NOTE:

If you are unsure how to connect your oven, please consult an authorised, qualified electrician.

Neither the manufacturer nor the dealer can accept any liability for damage to the oven or personal injury resulting from failure to observe the correct electrical connection procedure.

Water vapour or drops may occasionally form on the oven walls or around the door seals and sealing surfaces. This is a normal occurrence and is not an indication of microwave leakage or a malfunction.



This symbol means that the surfaces are liable to get hot during use.

INSTALLATION



1. Remove all packing materials from the inside of the oven cavity.
2. Check the oven carefully for any signs of damage.
3. Place oven on a secure, level surface, strong enough to take the oven weight, plus the heaviest item likely to be cooked in the oven. Do not place the oven in a cabinet.
4. Select a level surface that provide enough open space for the intake and/or outlet vents. The rear surface of appliance shall be placed against a wall.
 - A minimum space of 20 cm is required between the oven and any adjacent walls.
 - Leave a minimum space of 30 cm above the oven.
 - Do not remove the feet from the bottom of the oven.
 - Blocking the intake and/or outlet openings can damage the oven.
 - Place the oven as far away from radios and TV as possible. Operation of microwave oven may cause interference to your radio or TV reception.

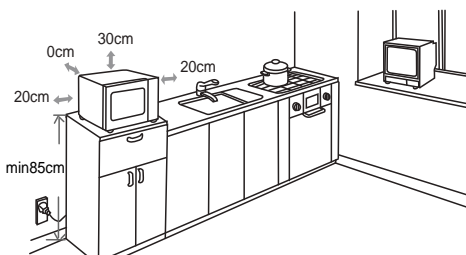

5. The oven door may become hot during cooking. Place or mount the oven so that the bottom of the oven is 85 cm or more above the floor. Keep children away from the door to prevent them burning themselves.
6. Securely connect the plug of the oven to a standard earthed (grounded) household electrical outlet.

WARNING: Do not place the oven where heat, moisture or high humidity are generated, (for example, near or above a conventional oven) or near combustible materials (for example, curtains). Do not block or obstruct air vent openings.

Do not place objects on top of the oven.



MICROWAVE POWER LEVELS

There are 5 microwave power levels available as listed below.

The microwave power level is varied by the microwave energy switching on and off. When using power levels other than HIGH you will be able to hear the microwave energy pulsing on and off as the food cooks or defrosts.

Generally the following recommendations apply:

High=800WATT used for fast cooking or reheating e.g. for casseroles, hot beverages, vegetables etc.

M.High = 620WATT used for longer cooking of dense foods such as roast joints, meat loaf and plated meals, also for sensitive dishes such as sponge cakes. At this reduced setting, the food will cook evenly without over cooking at the sides.

Med=400WATT for dense foods which require a long cooking time when cooked conventionally, e.g. beef casserole, it is advisable to use this power setting to ensure the meat will be tender.

M.Low=260WATT to defrost, select this power setting, to ensure that the dish defrosts evenly. This setting is also ideal for simmering rice, pasta, dumplings and cooking egg custard

LOW= 130WATT for gentle defrosting, e.g. cream gateaux or pastry.

Notice: When removing food from the oven, please ensure that the oven power is switched off by turning the timer switch to "0". Failure to do so, and operating the microwave oven without food in it, can result in overheating and damage to the magnetron.



GRILL POWER LEVELS (only for R-G20CA(B))

There are 4 grill power levels available as listed below.

Function/ Power	Output	Application
Combi.1	80% grill 20% micro.	Sausage, Lamb, Kabobs, Seafood, Steak
Combi.2	70% grill 30% micro.	Chicken pieces, Chicken breasts, Pork chops
Combi.3	60% grill 40% micro.	Whole chicken
Grill	100% grill	Baked bread, Slice food

Notice: When removing food from the oven, please ensure that the oven power is switched off by turning the timer switch to "0". Failure to do so, and operating the microwave oven without food in it, can result in overheating and damage to the magnetron.



MICROWAVE AND GRILL COOKING

1. Prepare and place food in a suitable container (refer to "SUITABLE OVENWARE" given on page E-8), position food/container directly onto the middle of the turntable. Close the door.
2. Turn the **MICROWAVE POWER CONTROL** knob to the desired setting; any one of the 5 microwave power levels and 4 grill power levels.
3. Turn the **TIMER/ DEFROST GUIDE** knob to the desired cooking/defrosting time and the oven will start automatically.
4. When cooking/defrosting is complete, the **TIMER/ DEFROST GUIDE** returns to "0" and the signal will sound. The oven lamp will turn off automatically and the turntable stops rotating. Open the oven door, remove the food/container carefully. Leave food to stand as required.

COOKING HINTS:

When the oven starts, the oven lamp will light and the turntable will rotate clockwise or anticlockwise.

If you wish to stop cooking before the cooking time has elapsed, turn the **TIMER/ DEFROST GUIDE** knob back to "0" (off), or open the oven door. The oven door can be opened at any time during cooking. To continue cooking, close the door. If you wish to change the cooking time during cooking, simply turn the **TIMER/ DEFROST GUIDE** knob to the desired new setting.

When cooking/defrosting for less than 3 minutes, turn the **TIMER/ DEFROST GUIDE** knob past the 10 minute mark, and then back to the desired setting. The timer will then run more accurately.

To change the power level during cooking, turn the **MICROWAVE POWER CONTROL** knob to the desired setting.

WARNING:

Ensure the **TIMER/ DEFROST GUIDE** is returned to "0" position at the end of cooking, or the oven will start automatically when the oven door is closed.

DEFROSTING GUIDE



This guide is designed to make defrosting specific foods easier. It can be used for defrosting: Chicken portions, chops, fish (whole or fillets), minced meat and sausages.

Example: To defrost 0.4 kg of chicken portions:

1. Place chicken portions in a flan dish, and place on the turntable into the oven.
2. Turn the **MICROWAVE POWER CONTROL** knob to DEFROST setting (MEDIUM LOW).
3. Turn the **TIMER/ DEFROST GUIDE** to 0.4 kg setting. The oven will start immediately. Turn the chicken portions over 1-2 times during defrosting.
4. After defrosting, cover the food in foil and leave to stand until thoroughly defrosted.

Note: The defrosting time is based on standard conditions. Please check the defrosting result and, if necessary, adjust the defrosting times accordingly.

SUITABLE OVENWARE



To cook/defrost food in a microwave oven, the microwave energy must be able to pass through the container to penetrate the food. Therefore it is important to choose suitable cookware.

Round/oval dishes are preferable to square/oblong ones, as the food in the corners tends to overcook. A variety of cookware can be used as listed below.

Cookware	Microwave Safe	Comments
Aluminium foil Foil Containers	✓ / ✗	Small pieces of aluminium foil can be used to shield food from overheating. Keep foil at least 2 cm from the oven walls, as arcing may occur. Foil containers are not recommended unless specified by the manufacturer, follow instructions carefully.
Browning dishes	✓	Always follow the manufacturers instructions. Do not exceed heating times given. Be very careful as these dishes become very hot.
China clay and ceramics	✓ / ✗	Porcelain, pottery, glazed earthenware and bone china are usually suitable, except for those with metallic decoration.
Glassware	✓	Care should be taken if using fine glassware as it can break or crack if heated suddenly.
Metal	✗	It is not recommended to use metal cookware as it will arc, which can lead to fire.
Plastic/Polystyrene e.g fast food containers	✓	Care must be taken as some containers warp, melt or discolour at high temperatures.
Cling film	✓	It should not touch the food and must be pierced to let the steam escape.
Freezer/Roasting bags	✓	Must be pierced to let steam escape. Ensure bags are suitable for microwave use.
Paper - Plates, cups and kitchen paper	✓	Do not use plastic or metal ties, as they may melt or catch fire due to the metal 'arcing'.
Straw and wooden Containers	✓	Only use for warming or to absorb moisture. Care must be taken as overheating may cause fire.
Recycled paper and newspaper	✗	Always attend the oven when using these materials as overheating may cause fire. May contain extracts of metal which will cause 'arcing' and may lead to fire.

WARNING:

When heating food in plastic or paper containers, monitor the oven due to the risk of ignition.



CARE AND CLEANING

CAUTION: DO NOT USE COMMERCIAL OVEN CLEANERS, STEAM CLEANERS, ABRASIVE, HARSH CLEANERS, ANY THAT CONTAIN SODIUM HYDROXIDE OR SCOURING PADS ON ANY PART OF YOUR MICROWAVE OVEN.

CLEAN THE OVEN AT REGULAR INTERVALS AND REMOVE ANY FOOD DEPOSITS - Keep the oven clean, or the oven could lead to a deterioration of the surface. This could adversely affect the life of the appliance and possibly result in a hazardous situation

Oven exterior

The outside of your oven can be cleaned easily with mild soap and water. Make sure the soap is wiped off with a moist cloth, and dry the exterior with a soft towel.

Control panel

Open the door before cleaning to de-activate the control panel. Care should be taken in cleaning the control panel. Using a cloth dampened with water only, gently wipe the panel until it becomes clean.

Avoid using excessive amounts of water. Do not use any sort of chemical or abrasive cleaner.

CAUTION:

Take care not to move the TIMER knob from "0" (off) position during cleaning, or the oven will start as soon as you close the door.

Oven Interior

1. For cleaning, wipe any splatters or spills with a soft damp cloth or sponge after each use while the oven is still warm. For heavier spills, use a mild soap and wipe several times with a damp cloth until all residues are removed. Do not remove the waveguide cover.

2. Make sure that mild soap or water does not penetrate the small vents in the walls which may cause damage to the oven.

3. Do not use spray type cleaners on the oven interior.

Keep the waveguide cover clean at all times.

The waveguide cover is constructed from a fragile material and should be cleaned with care (follow the cleaning instructions above).

NOTE: Excessive soaking may cause disintegration of the waveguide cover. The waveguide cover is a consumable part and without regular cleaning, will need to be replaced.

Turntable and Turntable support

Remove the turntable and turntable support stay from the oven.

Wash the turntable and turntable support in mild soapy water. Dry with a soft cloth. Both the turntable and the turntable support are dishwasher safe.

Door

To remove all trace of dirt, regularly clean both sides of the door, the door seals and adjacent parts with a soft, damp cloth. Do not use abrasive cleaner.

NOTE: A steam cleaner should not be used.

Cleaning tip - For easier cleaning of your oven:

Place half a lemon in a bowl, add 300 ml (1/2 pint) water and heat for 10 -12 minutes.

Wipe the oven clean using a soft, dry cloth.



Keep the power supply cord away from heated surface. If you think the oven is not working properly, there are some simple checks you can carry out yourself before calling an engineer.

Follow this simple check below: Place half a cup of water on the turntable and close the door. Programme the oven to cook for 1 minute.

1. Does the oven lamp come on when it is cooking?
2. Does the turntable rotate?
3. Does the cooling fan work? (Check by placing your hand above the air vent openings.)
4. After 1 minute does the audible signal sound?
5. Is the water in the cup hot?
6. After 3 minutes, does the grill heating element become red?

If you answer "NO" to any question, first check that the oven is plugged in properly and the fuse has not blown. If there is no fault with either, check against the troubleshooting chart below.

WARNING: Never adjust, repair or modify the oven yourself. It is hazardous for anyone other than a SHARP trained engineer to carry out servicing or repairs. This is important as it may involve the removal of covers that provide protection against microwave energy.

- The door seal stops microwave leakage during oven operation, but does not form an airtight seal. It is normal to see drops of water, light or feel warm around the oven door. Food with a high moisture content will release steam and cause condensation inside the door which may drip from the oven.
- **Repairs and Modifications:** Do not attempt to operate the oven if it is not working properly.
- **Outer Cabinet & Lamp Access:** Never remove the outer cabinet. This is very dangerous due to high voltage parts inside which must never be touched, as this could be fatal.
Your oven is not fitted with a lamp access cover. If the lamp fails, do not attempt to replace the lamp yourself, contact your nearest service centre approved by SHARP.

TROUBLESHOOTING CHART

QUERY	ANSWER
Draught circulates around the door.	When the oven is working, air circulates within the cavity. The door does not form an airtight seal so air may escape from the door.
Condensation forms in the oven, and may drip from the door.	The oven cavity will normally be colder than the food being cooked, and so steam produced when cooking will condense on the colder surface. The amount of steam produced depends on the water content of the food being cooked. Some foods, such as potatoes have a high moisture content. Condensation trapped in the door glass should clear after a few hours.
Flashing or arcing from within the cavity when cooking.	Arcing will occur when a metallic object comes into close proximity to the oven cavity during cooking. This may possibly roughen the surface of the cavity, but would not damage the oven.
Arcing potatoes.	Ensure all "eyes" are removed from the potatoes and that they have been pierced, place directly onto the turntable or in a heat resistant flan dish or similar.
The display is lit but the control panel will not work when pressed.	Check the door is closed properly.
Oven cooks too slowly.	Ensure correct power level has been selected.
Oven makes a noise.	The microwave energy pulses ON and OFF during cooking/defrosting.
Outer cabinet is hot.	The cabinet may become hot to touch - keep children away.

